



## M16 – Professional Outdoor Dual Lens Camera

### ■ High-Performance Dual Lens Camera For The Use Around the Clock

Automatic Switchover From Day To Night Sensor System

### ■ Modular System For Maximum Flexibility

Sensors And Lenses Can Easily Be Customized With Interchangeable Sensor Modules For Self-Assembly

### ■ Powerful, Intelligent And Flexible Mx6 System Platform

Simultaneous Streaming Of Up To Three Video Codecs (MxPEG, MJPEG And H.264)

### ■ Intelligent 3D Motion Detection

MxActivitySensor Integrated As Standard

### ■ Reduced Energy Costs

Power Consumption < 7 W, Standard PoE

### ■ Virtually Maintenance-Free

Weatherproof, IP66, -30 – 60°C

# Technical Specifications

## MOBOTIX M16 AllroundDual



Camera Variants	M16 Day	M16 Night	M16 Day & Night
Specialties	<b>Modular system:</b> M16 Body Mx-M16A with one or two sensor modules of choice (self-assembly)		<b>M16 Sets</b> with two factory-assembled sensor modules
Lenses, Sensors (Integrated Into Sensor Modules)	M16 Day	M16 Night	M16 Day & Night
Sensor module with Fisheye Lens B016 (103° x 77°), night version optionally with long-pass filter (LPF)	Mx-O-SMA-S-6D016	Mx-O-SMA-S-6N016 LPF: Mx-O-SMA-S-6L016	Self-assembly only
Sensor module with Ultra Wide Lens B036 (103° x 77°), night version optionally with LPF	Mx-O-SMA-S-6D036	Mx-O-SMA-S-6N036 LPF: Mx-O-SMA-S-6L036	<b>Mx-M16A-6D6N036</b> or self-assembly
Sensor module with Super Wide Lens B041 (90° x 67°), night version optionally with LPF	Mx-O-SMA-S-6D041	Mx-O-SMA-S-6N041 LPF: Mx-O-SMA-S-6L041	<b>Mx-M16A-6D6N041</b> or self-assembly
Sensor module with Wide Lens B061 (60° x 45°), night version optionally with LPF	Mx-O-SMA-S-6D061	Mx-O-SMA-S-6N061 LPF: Mx-O-SMA-S-6L061	<b>Mx-M16A-6D6N061</b> or self-assembly
Sensor module with Standard Lens B079 (45° x 34°), night version optionally with LPF	Mx-O-SMA-S-6D079	Mx-O-SMA-S-6N079 LPF: Mx-O-SMA-S-6L079	<b>Mx-M16A-6D6N079</b> or self-assembly
Sensor module with Tele Lens B119 (31° x 23°), night version optionally with LPF	Mx-O-SMA-S-6D119	Mx-O-SMA-S-6N119 LPF: Mx-O-SMA-S-6L119	<b>Mx-M16A-6D6N119</b> or self-assembly
Sensor module with Distant Tele Lens B237 (15° x 11°), night version optionally with LPF	Mx-O-SMA-S-6D237	Mx-O-SMA-S-6N237 LPF: Mx-O-SMA-S-6L237	<b>Mx-M16A-6D6N237</b> or self-assembly
Sensor module with Super Tele Lens B500 (8° x 6°), night version optionally with LPF	Mx-O-SMA-S-6D500	Mx-O-SMA-S-6N500 LPF: Mx-O-SMA-S-6L500	Self-assembly only
Sensor module with CS-Mount (no lens included)	Mx-O-SMA-S-6DCS	Mx-O-SMA-S-6NCS	Self-assembly only
Sensor module with CSVario Lens B045-100-CS	Mx-O-SMA-S-6DCSV	Mx-O-SMA-S-6NCSV	Self-assembly only
Hardware	M16 Day	M16 Night	M16 Day & Night
Image sensor with individual exposure zones	Color	Black and White (B/W)	Color & B/W
Light sensitivity in lux at 1/60 s and 1/1 s	0.1/0.005	0.02/0.001	0.1/0.005 (Color) 0.02/0.001 (B/W)
Image sensor (color or B/W sensor)	1/1.8" CMOS, 6MP (3072 x 2048), Progressive Scan		
Microprocessor	i.MX 6 Dual Core incl. GPU (1 GB RAM, 512 MB Flash)		
H.264 Hardware Codec	Yes, bandwidth limitation available; output image format up to QXGA		
Protection class M16 Body	IP66 and IK07		
Protection class M16 with 6MP sensor modules	IP66 with all modules; IK04 with B036 to B237; IK07 with B016		
Intended use	Not for use in hazardous areas (Ex area)		
Ambient temperature (range)	-30 to 60°C/-22 to 140°F		
Internal DVR, ex works	4 GB (microSD)		
Microphone/speaker	Yes/Yes		
16bit/16kHz HD wideband audio (Opus codec)	Yes (live and audio messages)		
Passive infrared sensor (PIR)	Yes		
Temperature sensor	Yes		
Shock detector (tamper detection)	Yes		
Power consumption (typical)	< 7 watts		
PoE Class (IEEE 802.3af)	Class 2 or 3 (variable), factory setting: class 3		
Interfaces Ethernet 100BaseT/MxBus/USB	Yes (MxRJ45)/No/Yes		
Interface RS232	With accessory (MX-232-IO-Box)		
Mounting options	Wall, pole or ceiling (wall and ceiling mount included)		
Dimensions Mx-M16A (height x width x depth)	210 x 158 x 207 mm		

# Technical Specifications

## MOBOTIX M16 AllroundDual



Hardware	M16 Day	M16 Night	M16 Day & Night
Weight Mx-M16A	1,160 g		
Housing	PBT-30GF, color: white		
Standard accessory	Screws, dowels, screw caps, 2 allen wrenches, module key, VarioFlex wall and ceiling mount with rubber sealing, 0.5 m ethernet patch cable, 1 blind module, QuickInstall		
Detailed technical documentation	www.mobotix.com > Support > Manuals		
Online version of this document	www.mobotix.com > Support > Spec Sheets		
MTBF	> 80,000 hours		
Certifications	EN55032:2012 EN55022:2010; EN55024:2010; EN50121-4:2015 EN61000-6-1:2007; EN 61000-6-2:2005 EN61000-6-3:2007+A1:2011 EN61000-6-4:2007+A1:2011 AS/ NZS CISPR22:2009+A1:2010 CFR47 FCC part15B		
Protocols	IPv4, IPv6, HTTP, HTTPS, FTP, SFTP, RTP, RTSP, UDP, SNMP, SMTP, DHCP (client and server), NTP (client and server), SIP (client and server) G.711 (PCMA and PCMU) and G.722		
Image Formats, Frame Rates, Image Storage	M16 Day	M16 Night	M16 Day & Night
Available video codecs	MxPEG/MJPEG/H.264		
Image formats	Freely configurable format 4:3, 8:3, 16:9 or customized format (Image Cropping), such as 2592x1944 (5MP), 2048x1536 (QXGA), 1920x1080 (Full-HD), 1280x960 (MEGA)		
Multistreaming	Yes		
Multicast stream via RTSP	Yes		
Max. image format (dual image from both sensors)	2x 6MP (6144 x 2048)		
Max. frame rate (fps, only single core used)	<b>MxPEG:</b> 42@HD(1280x720), 34@Full-HD, 24@QXGA, 15@5MP, 12@6MP, 6@2x 6MP <b>MJPEG:</b> 26@HD(1280x720), 13@Full-HD, 9@QXGA, 5@5MP, 4@6MP, 2@2x 6MP <b>H.264:</b> 25@Full-HD, 20@QXGA		
Number of images with 4 GB microSD (internal DVR)	CIF: 250,000, VGA: 125,000, HD: 40,000, QXGA: 20,000, 6MP: 10,000		
General Functions	M16 Day	M16 Night	M16 Day & Night
Digital zoom and pan	Yes		
ONVIF compatibility	Yes, complete ONVIF Profile S supported by future software update		
Genetec protocol integration	Yes		
Programmable exposure zones	Yes		
Snapshot recording (pre/post-alarm images)	Yes		
Continuous recording with audio (0.2 to 30 fps)	Yes		
Event recording with audio	Yes		
Time controlled flexible event logic	Yes		
Weekly schedules for recordings and actions	Yes		
Event video and image transfer via FTP and email	Yes		
Playback and QuadView via web browser	Yes		
Bidirectional audio in browser	Yes		
Animated logos on the image	Yes		
Master/Slave functionality	Yes		
Privacy zone scheduling	Yes		

# Technical Specifications

## MOBOTIX M16 AllroundDual



General Functions	M16 Day	M16 Night	M16 Day & Night
Customized voice messages		Yes	
VoIP telephony (audio/video, alert)		Yes	
Remote alarm notification (network message)		Yes	
Programming interface (HTTP-API)		Yes	
DVR/Storage Management	Inside camera via microSD card, externally via USB device and NAS, different streams for live image and recording, MxFFS with archive function, pre-alarm an post-alarm images, monitoring recording with failure reporting		
Camera and data security	User and group management, SSL connections, IP-based access control, IEEE802.1x, intrusion detection, digital image signature		
MxMessageSystem: Sending and receiving of MxMessages		Yes	
Video Analysis	M16 Day	M16 Night	M16 Day & Night
Video motion detector		Yes	
MxActivitySensor		Yes	
Video Management Software	M16 Day	M16 Night	M16 Day & Night
MxManagementCenter		Yes	
Mobile MOBOTIX App		Yes	

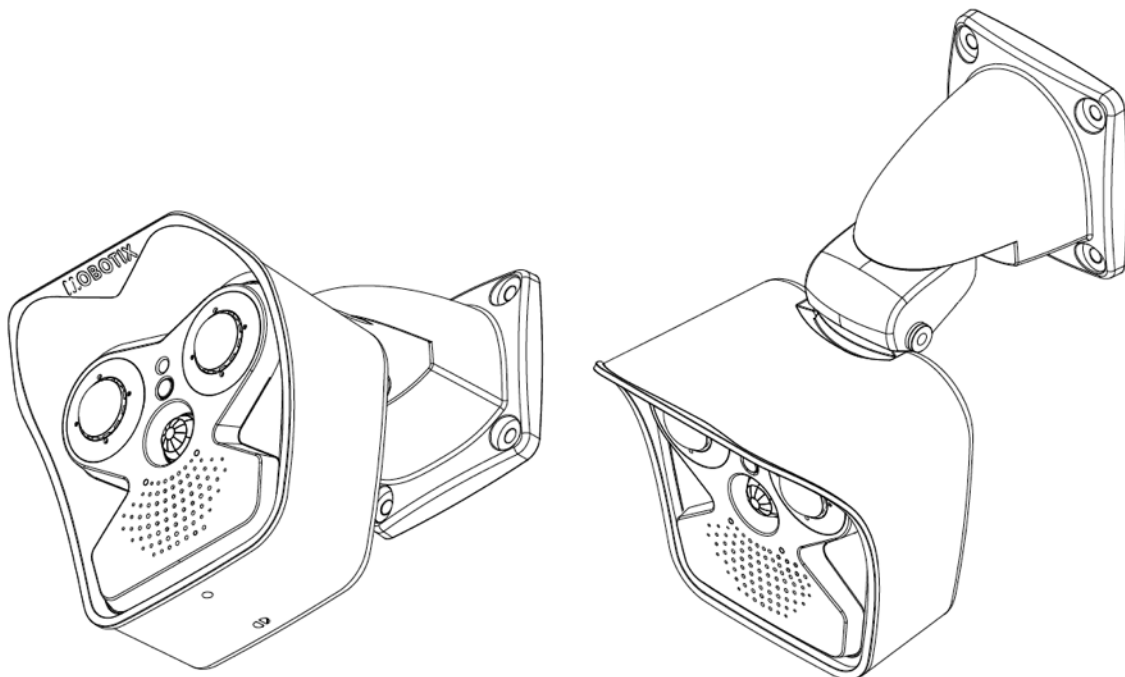

# Technical Specifications

## MOBOTIX M16 AllroundDual

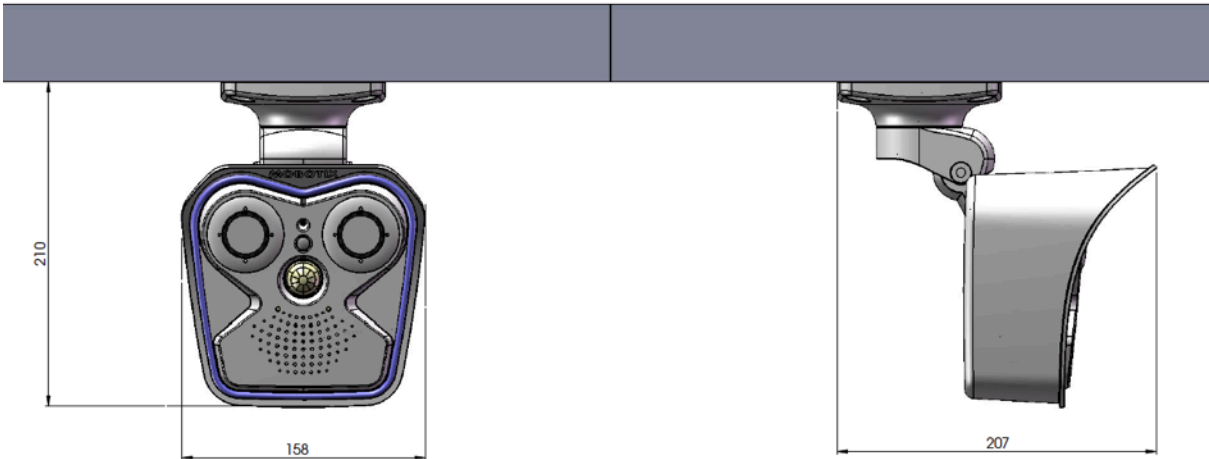
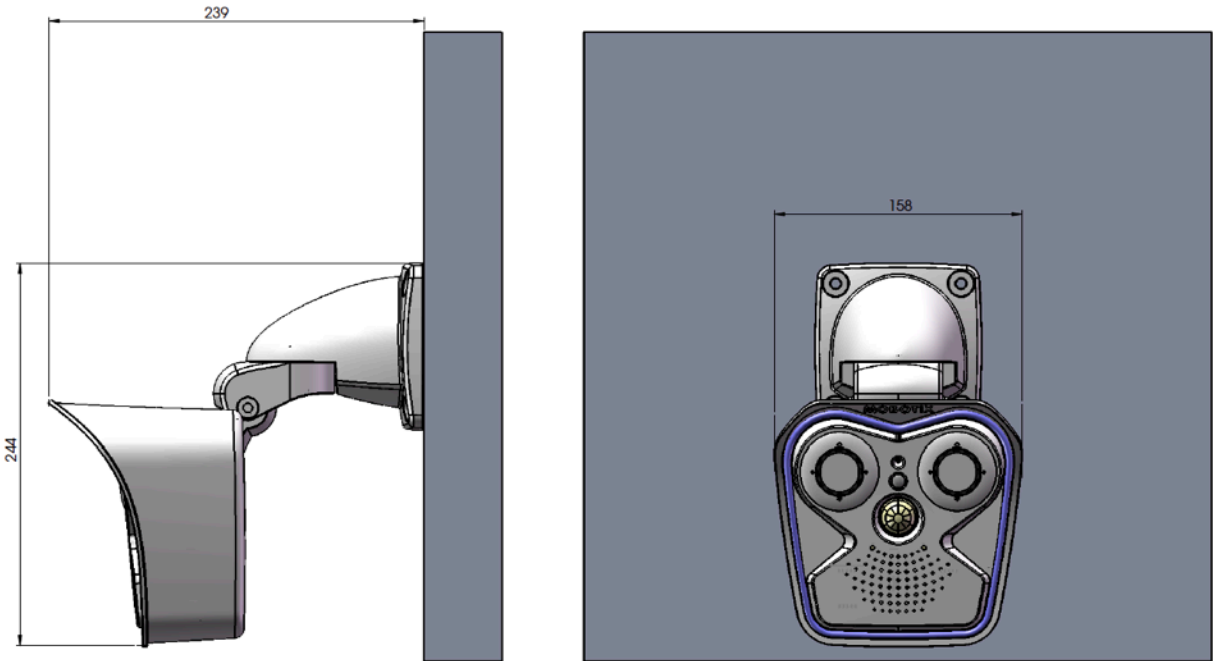

All dimensions in mm

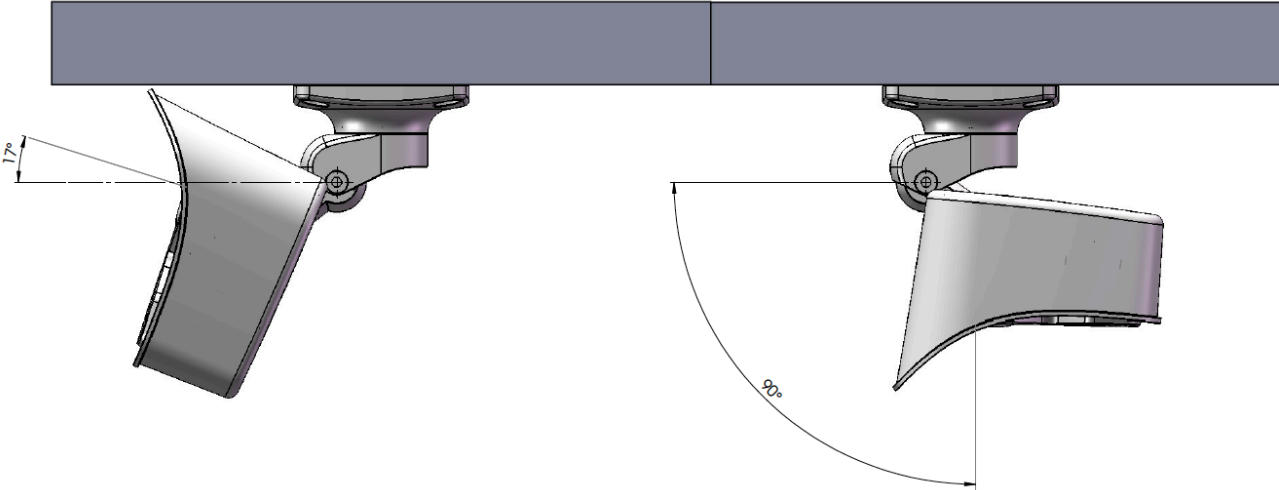

# Technical Specifications

## MOBOTIX M16 AllroundDual

