

PLEASE CONFIRM AND SIGN BACK!

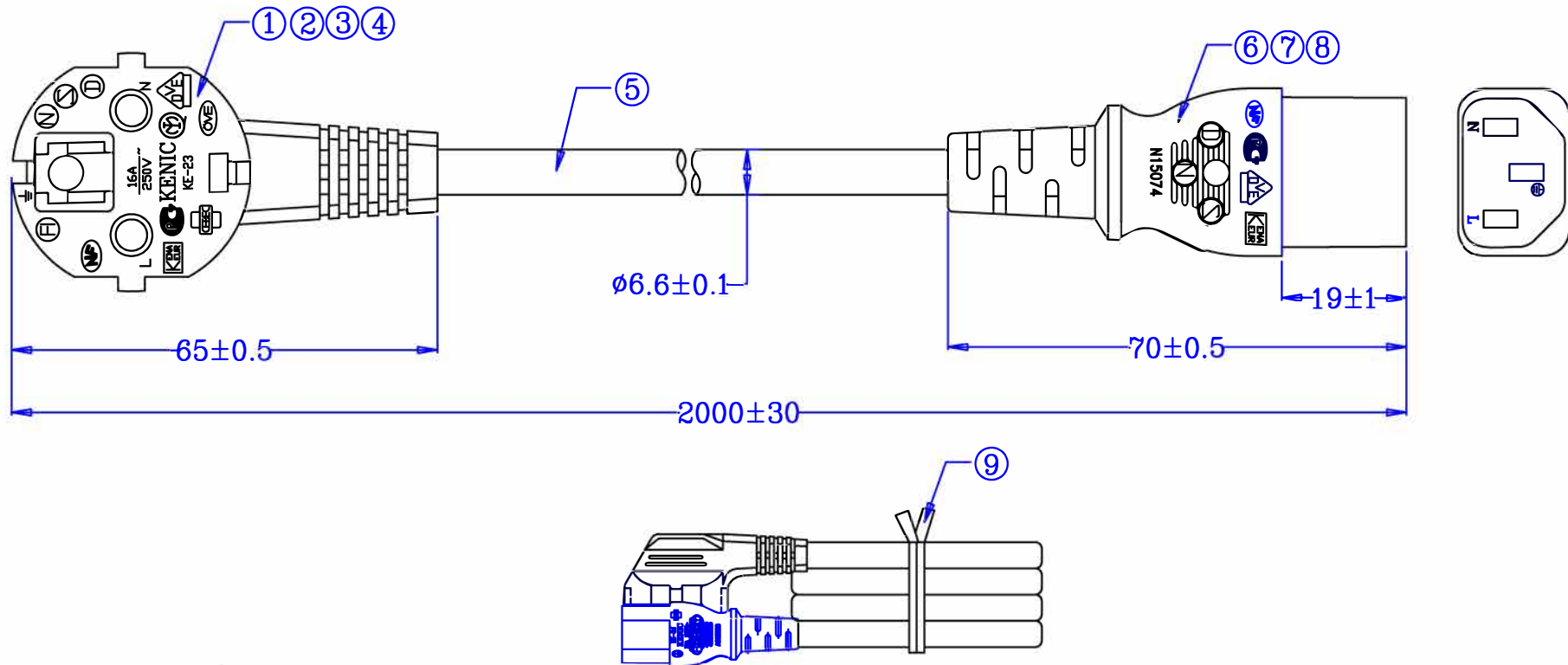

10	WEIGHT	/			
9	TIE	/	PE TIE	1PC	BLACK
8	MODEL	BK01P90EX	KE-24 MODEL PVC	18.5 g	BLACK
7	INNER	MA-034-01	NYLON	1PC	BLACK
6	TERMINAL	MA-003-01	U TYPE BRASS TERMINAL	3PCS	/
5	CABLE	BK01W81DX	H05VV-F 3G 0.75mm <sup>2</sup> BLACK	1980±15	BLACK
4	BUSHING	/	TYPE:4.0*12MM	/	/
3	INNER	MA-023-02	NYLON	1PC	BLACK
2	MODEL	BK01P90EX	KE-23 MODEL PVC	42.3 g	BLACK
1	PLUG PIN	MA-023-01	EUROPE PLUG	1PC	BLACK
NO.	NAME	MATERIAL	DESCRIPTION	QTY	COLOUR

<b>KENIC</b> KENIC ELECTRIC MFG. CO, LTD.					
NAME	KE-23+KE-24	UNIT	mm		
PLUG STANDARD	IEC 60884-1 EN 60320 C13	SCALE	/	DATE	2006.12.07
CABLE STANDARD	VDE 0281	REV.	A	DRAWN	Y.L.L
DRAWING NO.	/	EXTERNAL DRAWING	/	CHECKED	L.L.Z
CUSTOMER P/N	CAAL/SC			APPROVED	Z.W.G