

SUBJECT: SCOPE OF DOCUMENT

CONTAINS :

1-0 General Description

2-0. Input Requirements

3-0. Output Requirements

4-0. Reliability

5-0. Environment

6-0. Safety

7-0. Mechanical Characteristics

1-0. General Description

The purpose of the document is to specify a Single phase AC input, single output switching power supply. This specification is suitable for: **EA10731K Series**

This product is AC to DC switching power transfer device, it can provide for a **24V, 2.5A max & 60W max** DC output with constant voltage source.

This Specification defines the input, output, performance characteristics, environment, noise and safety requirement for a power supply.

2-0. Input Requirements

2-1. AC Input Voltage

Maximum Voltage: 264Vac

Normal Voltage: 100~240Vac

Minimum Voltage: 90Vac

2-2. AC Input Frequency

Maximum Frequency: 63Hz

Normal Frequency: 50~60Hz

Minimum Frequency: 47Hz

2-3. Input Current

2.0A (Max.) @ 100Vac/60Hz-240Vac/50Hz with full load.

2-4. Energy saving standards:

2-4-0. Designed to meet the following standard :

CoC Tier II

2-4-1. Efficiency

89.0% (avg.) at 115Vac/60Hz & 230Vac/50Hz input voltage and 25%, 50%, 75% & 100% of max output current.

79% at 115Vac/60Hz & 230Vac/50Hz input voltage and 10% of max output current

2-4-2 No Load Power Consumption.

No Load Watt < **0.15W** at normal line input.

2-5. Configuration

3-wire AC input (Line ,Neutral, FG)

2-6. Input Fuse

The hot line side of the input shall have a fuse, rating (3.15A/250V)

2-7. Inrush Current

60A at 110 Vac

120A at 220 Vac At cold start, maximum load.

2-8. Line Regulation

This line regulation is less than $\pm 1\%$, of rated output voltage @ full load .

2-9. Hold Up Time

8.3 mSec., @ Normal line, with full load.

2-10. Rise Time

50 mSec., @ 115V AC input, with full load.

From 10% to 90% of output voltage.

2-11. Turn-ON Time

The output voltage should rise to 90% of rated output voltage in less than 3 SEC. from AC apply to 110Vac start up.

3-0. Output Requirements

3-1. Output Voltage and Current

Output Voltage (Vdc)	Current Min.(A)	Current Max.(A)
+24V	0	2.5A

(PS: Vo tolerance is +10%, -10 when it into peak condition)

3-2. Load Regulation

Voltage (Vdc)	Tolerance (%)	Regulation (Vdc)
+24V	+5/, -5	22.8~25.2V

3-3. Dynamic Load Regulation

$\pm 5\%$ excursion for 50% - 100% or 100% - 50% load change of DC output at any frequency up to 1KHz(duty 50%)

3-4. Ripple & Noise

The power supply shall not exceed the following limits on the indicated voltage for 60Hz or 50Hz ripple, Switching frequency ripple and noise and dynamic load variations measured with a 20MHz bandwidth

Output	Ripple/Noise
+24V	1.5% max. of rated output voltage

Input condition : for rated voltage , Output condition : for max load
Ripple / Noise: 60Hz ripple + switching ripple and noise
Ripple & Noise are measured at the end of output cable which are added a 0.1uF ceramic capacitor and a 47uF electrolytic capacitor

3-5. Over Voltage Protection

175% Max. of rated voltage.

The output voltage shall be shutdown and auto-recover mode when OVP occurred.

3-6. Over Current Protection

110~200% output current. At 100-240Vac input,

The adapter can withstand continuous short at DC output and no damage.

It will enter into normal condition if the fault condition is removed.

3-7. Stability

2% Max. at constant load with constant input (after **30 minutes** of operation).

3-8. Temperature Rise (Optional)

Less than 45 on top/bottom case at normal AC input & 80% load of DC output at environment temperature 25 .

3-9. Drop-out

Output voltage shall remain within the specified regulation range, through the absence of a line input during 1/2 cycle, at full load and normal AC line input

3-10. Voltage Isolation

The DC ground will be isolated from the AC neutral and AC line.

4-0. Reliability

4-1. MTBF (MIL-HDBK-217F)

The power supply shall be designed and produced to have a mean time between failure (MTBF) of 100,000 hours at 25 degrees C.

5-0. Environment

5-1 Temperature

- a. Operating : 0 to 40
- b. Storage : -20 to 85

5-2 Humidity

- a. Operating : 10 to 90 %
- b. Storage: 5 to 90 %

5-3 Altitude

From sea level to 5,000 Meters (operation) and 5,000 Meters (no operation)

6-0. Safety

6-1. Hi-Pot Test

3000Vac/4242VDC, 3mA 2Sec. between primary and secondary circuit
L,N to FG 1800Vac 3mA 2Sec.

6-2. Insulation Test

500Vdc, 2 Sec. between primary and secondary circuit
IR should **50 MΩ.**

6-3. Leakage Current

500 uA, at 240Vac/50 Hz

6-4. Safety

UL, CUL, TUV, CB, CE, FCC, CCC, BSMI, EK, PSE, RCM

6-5. EMS

Items	Specification	Reference
ESD	Contact: $\pm 4KV$	IEC 61000-4-2
	Air: $\pm 8KV$	
RS	Frequency: 1KHz Field Strength: 3V/M	IEC 61000-4-3
EFT	1.0 KV on input AC power ports.	IEC 61000-4-4
SURGE	Line to Line: $\pm 1KV$ (peak)	IEC 61000-4-5
	Line to F.G : $\pm 2KV$ (peak)	

6-6. EMI

Comply with Standards
CISPR 32, EN 55032 Class B
FCC (PART 15 CLASS B)

7-0. Mechanical Characteristics

7-1. Physical Size : 105.5mm (L) * 46mm (W) * 28mm (H)

7-2. Enclosure material : 94V-0 minimum

7-3. Output Cable (Reference) : UL2468 #18

7-4. Vibration Test

The vibration frequencies are set at 20Hz, with total amplitude of 1.5mm
Along the 3 directions namely X-Y-Z. The each direction should be vibrated
for 60 minutes, after testing no abnormal electrical or mechanical should occur.

7-5. Drop Test (Referencing to CSA C22.2 No.950/UL1950/UL1310/EN62368)

Products shall be dropped from a height of 1000 mm onto a horizontal surface
consists of hardwood at 13mm thick , mounted on two layers of plywood each
19mm to 20mm thick , all supported on a concrete or equivalent non-resilient
floor. Upon conclusion of test , the equipment cannot into hazardous moving
parts and hazardous voltage circuits need be operational , and need meet Hi-Pot
specification requirement..

7-6. Net Weight (Reference) : 300 g

69.3

EDAC EDACPOWER ELEC.
AC ADAPTER 电源适配器 電源供應器 직류전원장치
MODEL 型号 型號 모델명 :EA10731K-240
AC INPUT 输入 輸入 정격입력 :100-240Vac, 2.0A, 50-60Hz
DC OUTPUT 输出 輸出 정격출력 :24.0V==2.5A 60.0W

Local Rep: HANJUN Corporation
 Tel : +82-54-461-0629
 KTL: SU10315-20001
 R-R-EPE-EA10731K-240

CE

최저소비효율기준 만족 제품
 제조업자명: EDAC Power Electronics (Suzhou) Co., Ltd

UL US LISTED
 I.T.E. POWER SUPPLY
 41TJ
 E209833 LPS

TUV SUD
 R33147
 RoHS

FC

RoHS

CAUTION 注意 注意
 FOR INDOOR USE ONLY 室内产品使用 室内產品使用
 I.T.E. USE ONLY

DATE CODE:

20	21	22			1	2	3	4	5
1	2	3	4	5	6	7	8	9	0

出厂日期 出廠日期

13128

C1	C3
----	----

CCC VI 10 TUV SUD PS E

制造商: 翠胜电子股份有限公司

MADE IN CHINA 中国制造 中國製造

36.2

2.5

2.5

R1*3

EDAC P/N.: 3128
 Background: Black color
 Character: Silver color
 Unit: mm

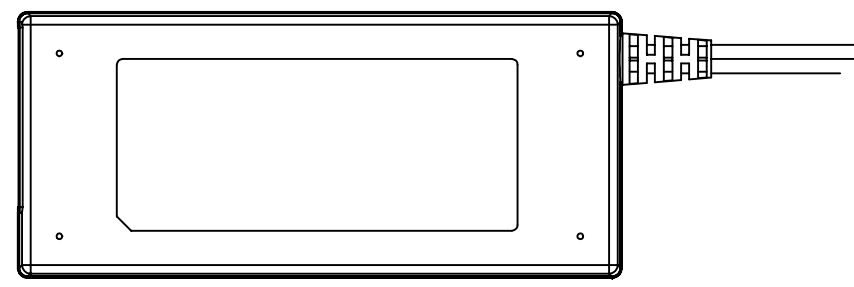
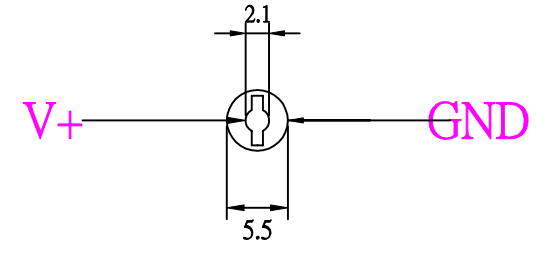
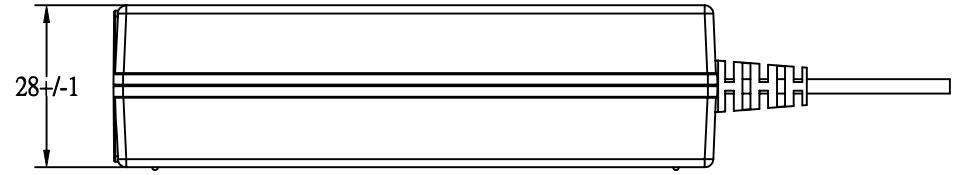
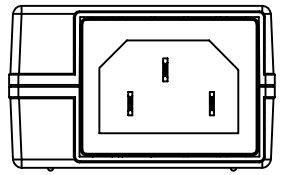
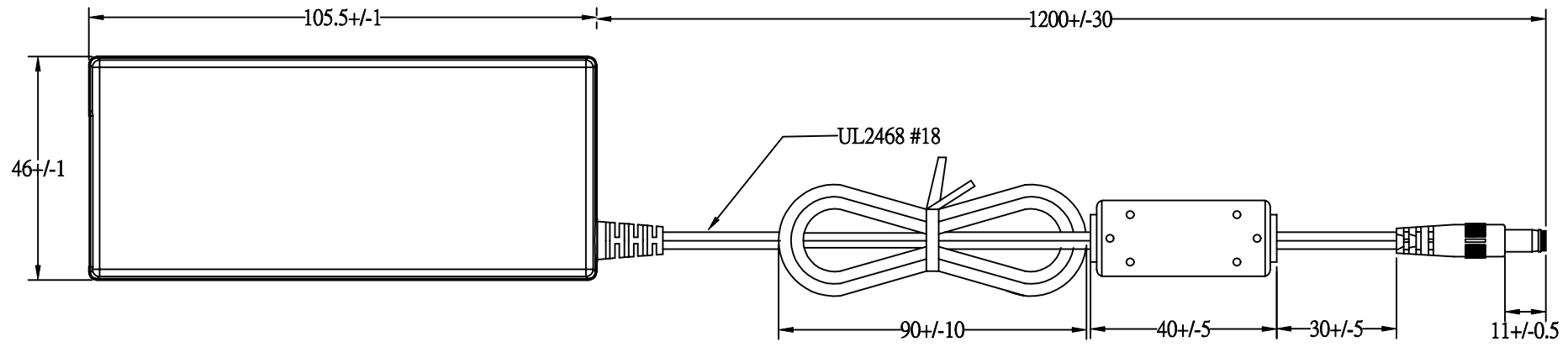

EDAC POWER ELEC.				APPROVED
MODEL	EA10731K(T01)	UNIT	mm	DESIGNED
color	BLACK	SCALE		CHECK
cus.		DATE	2020-05-15	DRAWING L.J.YU