

PC LAYOUT  
(COMPONENT SIDE  
-SOCKET OMITTED  
FOR CLARITY)

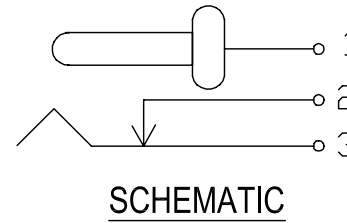

ISS.	AMEND	DATE
1	ISSUED	28/07/2011
2	NOTE 3 ADDED	06/10/2011
3	LAYOUT O/LINE ADDED	14/03/2012

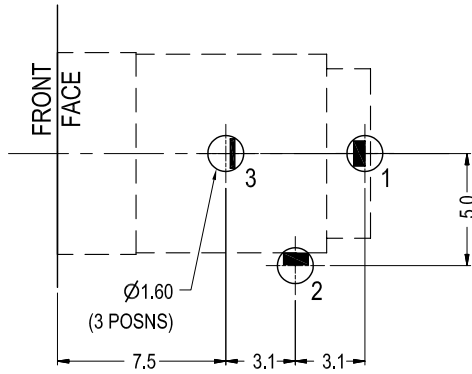
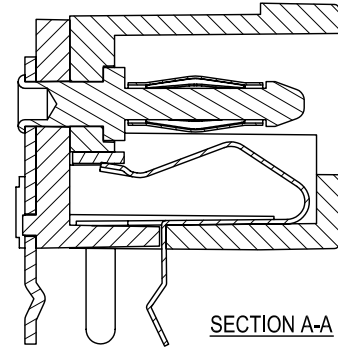
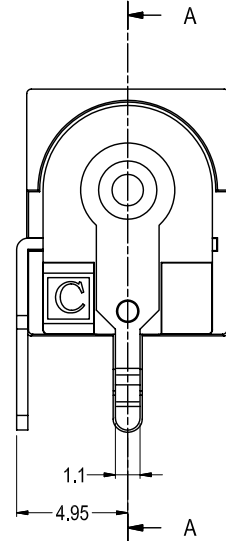
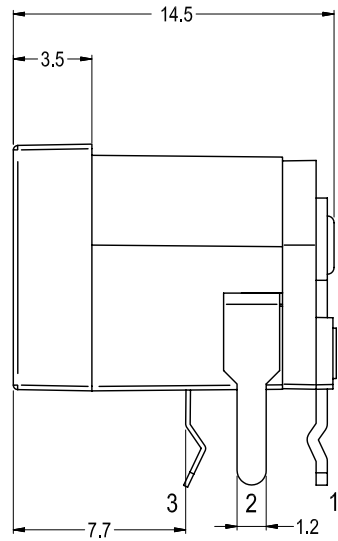
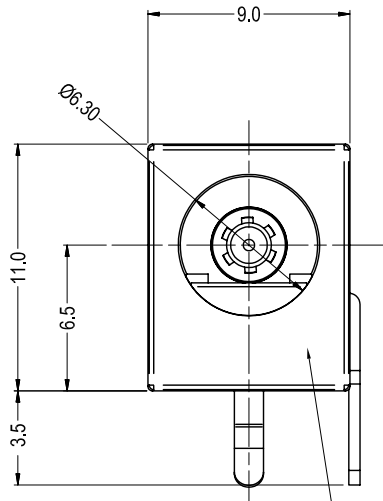

**NOTES:-**

- SUITABLE FOR USE WITH Ø2.1mm OR Ø2.5mm DC PLUG.
- RATED: 5A / 12V DC.  
LIFE: 5,000 INSERTIONS MINIMUM.  
INSULATION RESISTANCE BETWEEN ANY OPEN CONTACT  
>100MW @ 500V DC.
- HOUSING MATERIAL: PBT 30% GF TO UL94 V-0 (3.2mm)  
(CHANG CHUN PLASTIC PBT4830)

ALTERNATIVE  
LOGO POSITION

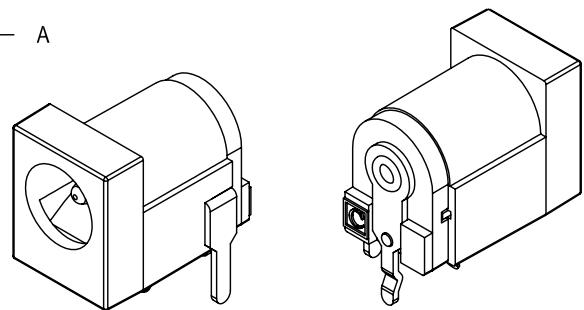

<b>RoHS</b> COMPLIANT
<b>TOLERANCE</b>
NO DEC. PLACE ±
1 DEC. PLACE ±
2 DEC. PLACE ±
HOLE Ø ±
ANGLES ±
UNLESS OTHERWISE STATED
DO NOT SCALE

**Cliff Electronic Components Ltd.**  
76 Holmehorpe Avenue, Holmehorpe Industrial Estate,  
Redhill, Surrey, RH1 2PF, England, UK  
Tel: 01737-771375 Fax: 01737-766012 Website: www.cliffuk.co.uk

THE CONTENTS OF THIS DOCUMENT MUST NOT BE COPIED OR DISCLOSED TO A 3rd PARTY WITHOUT WRITTEN PERMISSION OF CLIFF UK. © 2011

DIMENSIONS IN MILLIMETERS UNLESS OTHERWISE STATED. WORK TO DIMENSIONS. REMOVE ALL BURRS. IF IN DOUBT ASK.

MATERIAL: PBT / BRASS / PhBrz / BeCu

FINISH: AS MOULDED / SILVER PLATED TAGS

DRAWN: NJB APPROVED: DPJ

3rd ANGLE PROJECTION:

TITLE: DC10LP SOCKET (PCB MOUNT)

DRWG. No. **FC 681465P** FORM: A4DRWGH