

SEN-VIB01

Analog piezoelectric vibration sensor

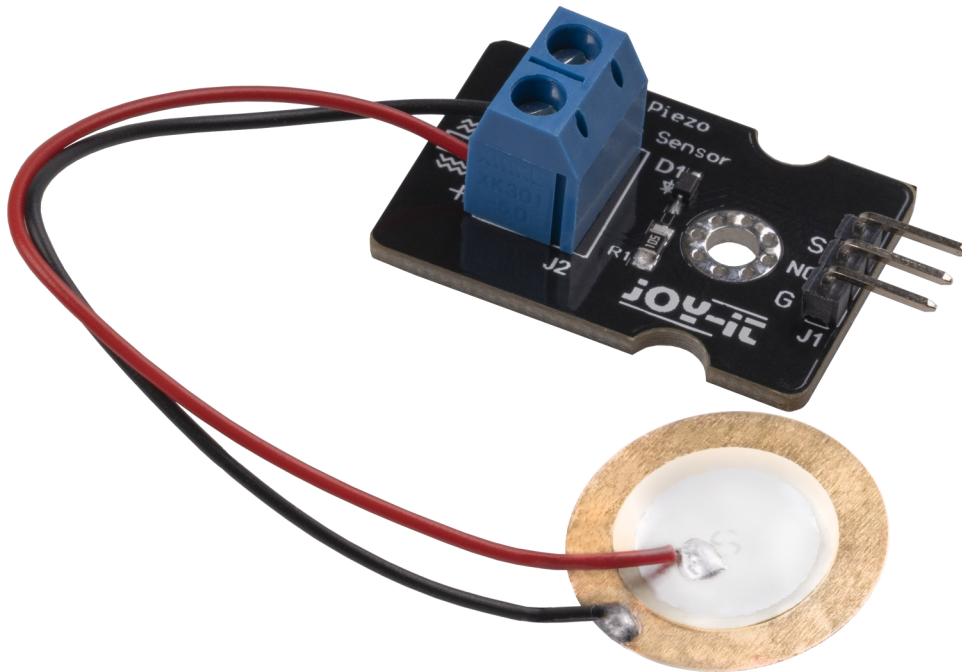

1. GENERAL INFORMATION

Dear customer,
thank you very much for choosing our product.
In the following, we will introduce you to what to observe while starting up and using this product.
Should you encounter any unexpected problems during use, please do not hesitate to contact us.

2. INTRODUCTION

Vibrations that affect the sensor generate a voltage signal due to the piezoelectric effect depending on the strength of the vibration. Therefore, you do not need a supply voltage for the sensor, but only the voltage at the signal pin of the sensor has to be measured by using an analog-digital converter.

3. USE WITH THE ARDUINO

3.1 Wiring

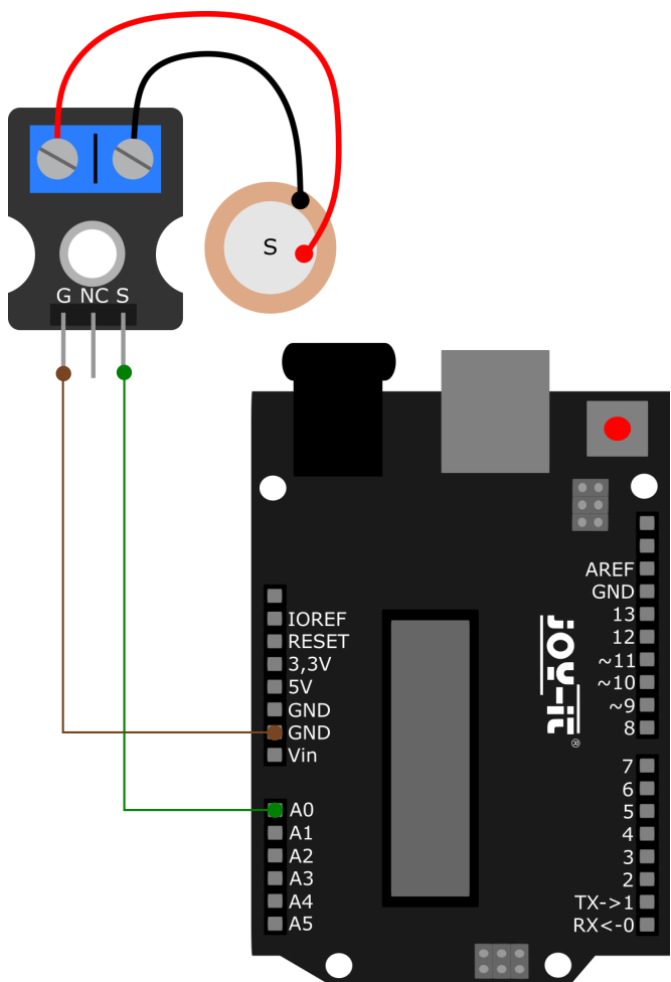

Arduino	SEN-VIB01
GND	G
-	NC
A0	S

3.2 Code example

We provide a code example for you to test your sensor. Before uploading, make sure that the correct **Board** and **Port** are set in your Arduino IDE under **Tools**.

The sensor generates a voltage from the vibration applied to it.

The following code will give you the current output voltage of the sensor. The higher the applied vibration, the higher the output voltage.

```
void setup() {  
  // put your setup code here, to run once:  
  Serial.begin(115200);  
}  
  
void loop() {  
  // put your main code here, to run repeatedly:  
  int sensorValue = analogRead(A0);  
  float voltage = sensorValue * (5.0 / 1023.0);  
  Serial.println(voltage);  
}
```

4. USE WITH THE RASPBERRY PI

4.1 Wiring

For use with the Raspberry Pi, an analog-digital converter is required. In this example we use the [COM-KY053ADC](#) from Joy-IT.

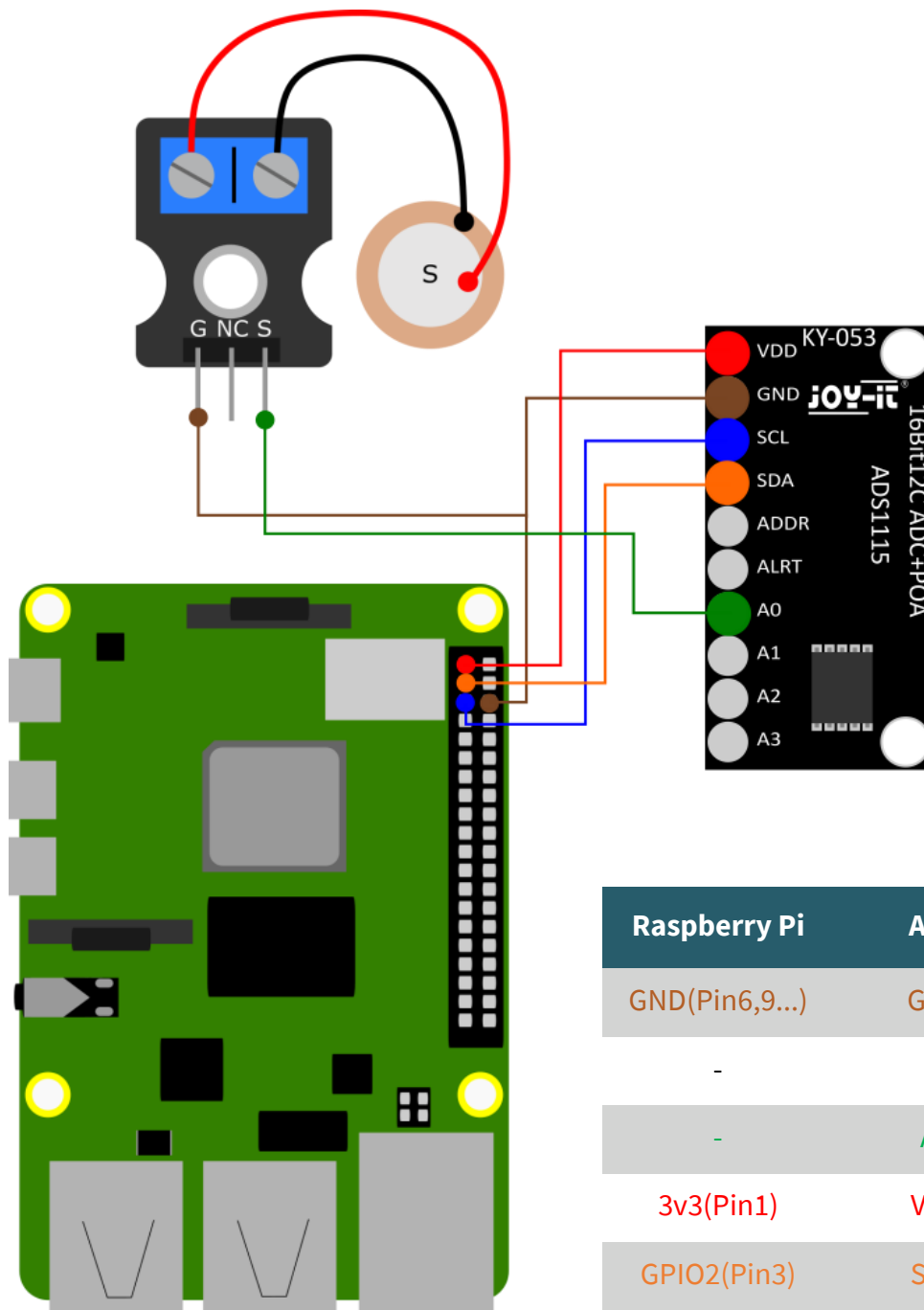

4.2 Installation

First you need to enable I2C on your Raspberry Pi. To open the configuration, enter the following command:

```
sudo raspi-config
```

There, select **3 Interface Options** → **P5 I2C**.

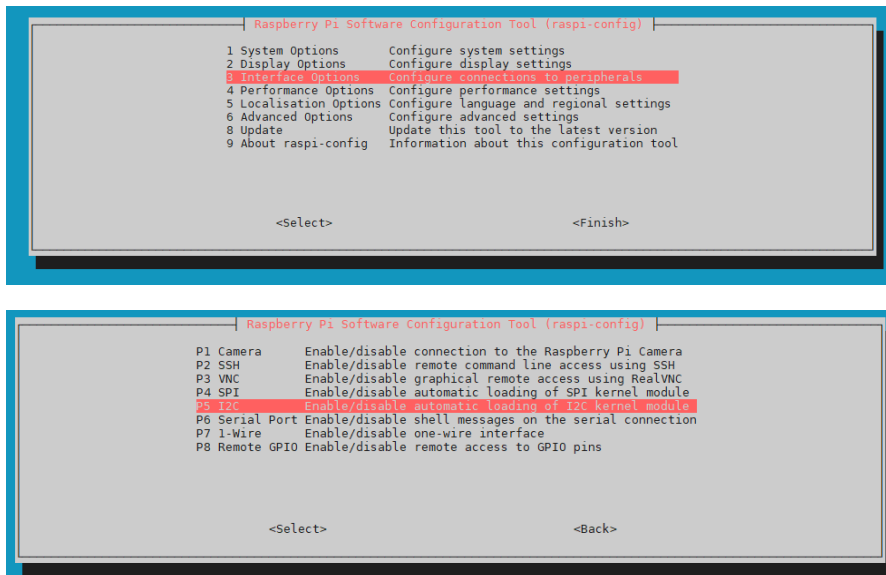

There you will be asked the question ***Would you like the ARM I2C Interface to be enabled?***. Confirm this with **Yes**.

You have now successfully activated I2C. The analogue-digital converter is now accessible under the I2C address 0x48.

For our code example, we use the [Adafruit Python ADS1x15](#) library, which was published under the [MIT-Lizenz](#). Use the following commands to download and install this library.

```
sudo apt-get install python3-pip
sudo apt-get install python3-smbus i2c-tools -y
sudo pip3 install adafruit-circuitpython-ads1x15
```

4.3 Code example

We provide you with a code example to test your sensor.

The sensor generates a voltage due to the vibration applied to it.

The following code will give you the current output voltage of the sensor. The higher the applied vibration, the higher the output voltage.

```
import time
import board
import busio
import adafruit_ads1x15.ads1115 as ADS
from adafruit_ads1x15.analog_in import AnalogIn

# Create the I2C bus
i2c = busio.I2C(board.SCL, board.SDA)

# Create the ADC object using the I2C bus
ads = ADS.ADS1115(i2c)

# Create single-ended input on channels
chan0 = AnalogIn(ads, ADS.P0)

while True:
    print("channel 0: ", "{:>5.3f}".format(chan0.voltage))
    print("-----")
    time.sleep(1)
```

5. ADDITIONAL INFORMATION

Our information and take-back obligations according to the Electrical and Electronic Equipment Act (ElektroG)

Symbol on electrical and electronic equipment:



This crossed-out dustbin means that electrical and electronic appliances do not belong in the household waste. You must return the old appliances to a collection point.

Before handing over waste batteries and accumulators that are not enclosed by waste equipment must be separated from it.

Return options:

As an end user, you can return your old device (which essentially fulfils the same function as the new device purchased from us) free of charge for disposal when you purchase a new device.

Small appliances with no external dimensions greater than 25 cm can be disposed of in normal household quantities independently of the purchase of a new appliance.

Possibility of return at our company location during opening hours:

SIMAC Electronics GmbH, Pascalstr. 8, D-47506 Neukirchen-Vluyn, Germany

Possibility of return in your area:

We will send you a parcel stamp with which you can return the device to us free of charge. Please contact us by email at Service@joy-it.net or by telephone.

Information on packaging:

If you do not have suitable packaging material or do not wish to use your own, please contact us and we will send you suitable packaging.

6. SUPPORT

If there are still any issues pending or problems arising after your purchase, we will support you by e-mail, telephone and with our ticket support system.

Email: service@joy-it.net

Ticket system: <http://support.joy-it.net>

Telephone: +49 (0)2845 9360-50 (10-17 o'clock)

For further information please visit our website:

www.joy-it.net