

***Technical Manual***  
***Of***  
***Intel Elkhart Lake Series CPU***  
***Based IPC M/B***

***NO. G03-MF13-F***

***Revision: 4.0***

***Release date: December 11, 2023***

**Trademark:**

- \* Specifications and Information contained in this documentation are furnished for information use only, and are subject to change at any time without notice, and should not be construed as a commitment by manufacturer.

---

---

## Environmental Protection Announcement

Do not dispose this electronic device into the trash while discarding. To minimize pollution and ensure environment protection of mother earth, please recycle.



---

---

# **TABLE OF CONTENT**

ENVIRONMENTAL SAFETY INSTRUCTION .....	iv
USER'S NOTICE .....	v
MANUAL REVISION INFORMATION .....	v
ITEM CHECKLIST .....	v
<b>CHAPTER 1 INTRODUCTION OF THE MOTHERBOARD</b>	
1-1 FEATURE OF MOTHERBOARD .....	1
1-2 SPECIFICATION .....	2
1-3 LAYOUT DIAGRAM .....	4
<b>CHAPTER 2 HARDWARE INSTALLATION</b>	
2-1 JUMPER SETTING .....	7
2-2 CONNECTORS AND HEADERS .....	13
2-2-1 CONNECTORS .....	13
2-2-2 HEADERS .....	17
2-2-3 Maximum Voltage & Current Limit .....	21
<b>CHAPTER 3 INTRODUCING BIOS</b>	
3-1 ENTERING SETUP .....	22
3-2 BIOS MENU SCREEN .....	23
3-3 FUNCTION KEYS .....	24
3-4 GETTING HELP .....	24
3-5 MEMU BARS .....	24
3-6 MAIN MENU .....	25
3-7 ADVANCED MENU .....	26
3-8 CHIPSET MENU .....	39
3-9 SECURITY MENU .....	41
3-10 BOOT MENU .....	44
3-11 SAVE & EXIT MENU .....	45



## Environmental Safety Instruction

---

- Avoid the dusty, humidity and temperature extremes. Do not place the product in any area where it may become wet.
- 0 to 60 centigrade is the suitable temperature. (The figure comes from the request of the main chipset)
- Generally speaking, dramatic changes in temperature may lead to contact malfunction and crackles due to constant thermal expansion and contraction from the welding spots' that connect components and PCB. Computer should go through an adaptive phase before it boots when it is moved from a cold environment to a warmer one to avoid condensation phenomenon. These water drops attached on PCB or the surface of the components can bring about phenomena as minor as computer instability resulted from corrosion and oxidation from components and PCB or as major as short circuit that can burn the components. Suggest starting the computer until the temperature goes up.
- The increasing temperature of the capacitor may decrease the life of computer. Using the close case may decrease the life of other device because the higher temperature in the inner of the case.
- Attention to the heat sink when you over-clocking. The higher temperature may decrease the life of the device and burned the capacitor.

---

---

## USER'S NOTICE

COPYRIGHT OF THIS MANUAL BELONGS TO THE MANUFACTURER. NO PART OF THIS MANUAL, INCLUDING THE PRODUCTS AND SOFTWARE DESCRIBED IN IT MAY BE REPRODUCED, TRANSMITTED OR TRANSLATED INTO ANY LANGUAGE IN ANY FORM OR BY ANY MEANS WITHOUT WRITTEN PERMISSION OF THE MANUFACTURER.

THIS MANUAL CONTAINS ALL INFORMATION REQUIRED TO USE THIS MOTHER-BOARD SERIES AND WE DO ASSURE THIS MANUAL MEETS USER'S REQUIREMENT BUT WILL CHANGE, CORRECT ANY TIME WITHOUT NOTICE. MANUFACTURER PROVIDES THIS MANUAL "AS IS" WITHOUT WARRANTY OF ANY KIND, AND WILL NOT BE LIABLE FOR ANY INDIRECT, SPECIAL, INCIDENTAL OR CONSEQUENTIAL DAMAGES (INCLUDING DAMAGES FOR LOSS OF PROFIT, LOSS OF BUSINESS, LOSS OF USE OF DATA, INTERRUPTION OF BUSINESS AND THE LIKE).

PRODUCTS AND CORPORATE NAMES APPEARING IN THIS MANUAL MAY OR MAY NOT BE REGISTERED TRADEMARKS OR COPYRIGHTS OF THEIR RESPECTIVE COMPANIES, AND THEY ARE USED ONLY FOR IDENTIFICATION OR EXPLANATION AND TO THE OWNER'S BENEFIT, WITHOUT INTENT TO INFRINGE.

## Manual Revision Information

Reversion	Revision History	Date
4.0	Fourth Edition	December 11, 2023

## Item Checklist

- Motherboard
- Cable(s)

---

---

# Chapter 1

## Introduction of the Motherboard

### 1-1 Feature of Motherboard

- Onboard Intel® Elkhart Lake Series Processor, with low power consumption never denies high performance
- Support 1\* DDR4 3200MHz SO-DIMM, maximum capacity up to 32GB
- Support 2\* RS232/RS422/RS485 COM Ports
- Onboard 1\* M.2 M-key (2242/2280, SATA/PCIe Gen.3x2 interface) support NVMe
- Onboard 1\* M.2 E-key (2230, USB2.0/PCIe Gen.3x1 interface)
- Onboard 1\* M.2 B-key (3042/3052, USB3.1 interface)
- Support 1\* SATAIII (6Gb/s) Device & 1\* SIM card slot
- Support 1\* External USB 3.1(Gen.2), 1\* External USB 2.0, 2\* Internal USB 2.0
- Support 4\* i225V 2.5GbE RJ-45 LAN ports
- Onboard optional 32GB / 64GB eMMC (by order)
- Onboard Lockable 12V DC-in PWR jack
- Support CPU Over-Temperature protection
- Support CPU Over-Current/Under Voltage protection
- Support CPU Smart FAN
- Compliance with ErP standard
- Support Watchdog function
- Onboard TPM (by order)

## 1-2 Specification

Spec	Description
<b>Design</b>	<ul style="list-style-type: none"> <li>● 3.5" SBC Form Factor; PCB size: 148mm * 102mm</li> </ul>
<b>Embedded CPU</b>	<ul style="list-style-type: none"> <li>● Integrated with Intel® Elkhart Lake series CPU <i>*CPU model varies from different IPC options. Please consult your dealer for more information of onboard CPU.</i></li> </ul>
<b>Memory</b>	<ul style="list-style-type: none"> <li>● 1* DDR4 SO-DIMM slot Support 1* DDR4 3200MHz SO-DIMM up to 32GB <i>* <b>Note:</b> Memory clock supporting range is decided by specific CPU of the model. For more memory compatibility information please consults your local dealer.</i></li> </ul>
<b>Expansion Slot</b>	<ul style="list-style-type: none"> <li>● 1* M.2 E-key (2230, USB2.0/PCIe Gen.3x1 interface) (<b>M2E1</b>)</li> <li>● 1* M.2 B-key (3042/3052, USB3.1 interface; co-function with <b>SIMCARD1</b>) (<b>M2B1</b>)</li> <li>● <b>SIMCARD1</b>: 1* SIM card slot (co-function with <b>M2B1</b> slot)</li> </ul>
<b>LAN Chip</b>	<ul style="list-style-type: none"> <li>● Integrated with 4* Intel i225-V PCI-E 2.5Gigabit LAN chip</li> <li>● Support Fast Ethernet LAN function of providing 10/100/1000/2500Mbps Ethernet data transfer rate <i>* <b>Note:</b> 2500Mbps high-speed transmission rate is <b>only</b> supported over <b>CAT 5e UTP cable.</b></i></li> </ul>
<b>Storage</b>	<ul style="list-style-type: none"> <li>● 1* SATAIII 6Gb/s port</li> <li>● 1* M.2 M-key (2242/2280, SATA/PCIe Gen.3x2 interface) support NVMe (<b>M2M</b>)</li> <li>● Onboard <b>optional</b> 32GB / 64GB eMMC (<b>by order</b>)</li> <li>● <i>*<b>Note:</b> Onboard eMMC capacity depends on the actual model purchased as technical specifications may update, without prior notice</i></li> </ul>
<b>BIOS</b>	<ul style="list-style-type: none"> <li>● AMI Flash ROM</li> </ul>
<b>Rear I/O</b>	<ul style="list-style-type: none"> <li>● 1* Lockable 12V DC-in power Jack</li> <li>● 1* USB 3.1(Gen.2) port</li> <li>● 1* USB 2.0 port</li> <li>● 4* 2.5Gbps RJ-45 LAN ports</li> <li>● 1* RS232/RS422/RS485 COM Port (<b>COM1</b>)</li> </ul>

---

---

<b>Internal I/O</b>	<ul style="list-style-type: none"><li>● 1* 2-Pin internal 12V DC-in power connector</li><li>● 1* SATA Power-out connector</li><li>● 1* CPUFAN connector</li><li>● 1* Front panel header</li><li>● 1* LAN_LED header</li><li>● 1* 9-pin USB 2.0 header (Expansible to 2* USB 2.0 ports)</li><li>● 1* RS232/422/485 serial port header (<b>FP_COM2</b>)</li><li>● 1* PS/2 keyboard &amp; mouse header</li><li>● 1* SMBUS header</li><li>● 1* GPIO header</li><li>● 1* HDMI header</li></ul>
---------------------	---



---

---

## 1-3 Layout Diagram

### *Rear IO Panel Diagram:*

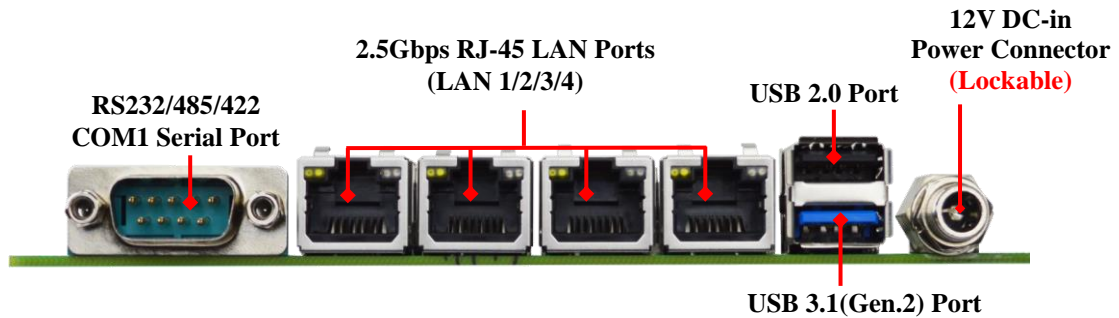

### **Warning!!**

The board has a 12V DC-in power connector (DCIN) in I/O back panel and an internal ATX12V (ATXPWR) power connector. User can only connect one type of compatible power supply to one of them to power the system.

## Motherboard Internal Diagram-Front Side

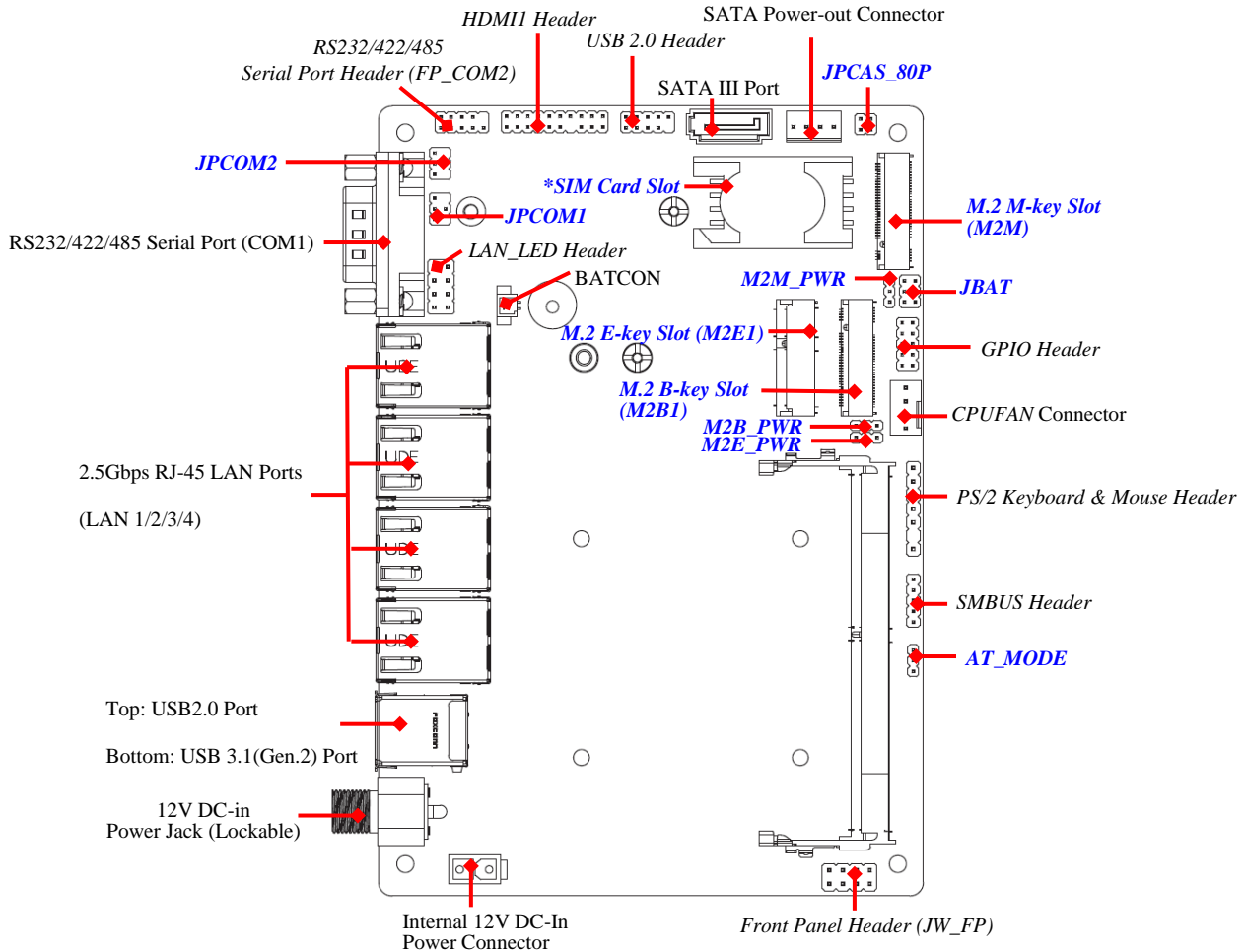

**\*Note:** M2B1 slot co-functions with SIM card; please install compatible 3G/4G/5G LTE card into SIM card holder as well for full function.

---

---

## Connectors

Connector	Name
DCIN1	Lockable 12V DC-in power Jack
USB31	<b>Top:</b> USB 2.0 Port Connector <b>Bottom:</b> USB 3.1(Gen.2) Port Connector
LAN1/2/3/4	2.5Gbps RJ-45 LAN Port Connector x 4
COM1	RS232/485/422 Serial Port Connector
ATXPWR	Internal 12V DC-in Power Connector
SATA1	SATAIII Connector
SATAPWR	SATA Power-out Connector
CPUFAN	CPUFAN Connector

## Headers

Header	Name	Description	Pitch
JW_FP	Front Panel Header(PWR LED/ HDD LED/Power Button /Reset)	8-pin Block	2.54mm
SMBUS	SMBUS Header	5-pin Block	2.0mm
PS2KBMS	PS/2 Keyboard & Mouse Header	6-pin Block	2.54mm
GPIO	GPIO Port Header	10-pin Block	2.0mm
FP_USB21	USB 2.0 Header	9-pin Block	2.0mm
HDMI1	HDMI Port Header	19-pin Block	2.0mm
FP_COM2	RS232/485/422 Serial Port Header	9-pin Block	2.0mm
LAN_LED	LAN Activity LED Header	8-pin Block	2.54mm

## Jumpers

Jumper	Name	Description	Pitch
AT_MODE	ATX Mode/AT Mode Select	3-Pin Block	2.0mm
JBAT	<b>Pin (1&amp;2):</b> Clear RTC <b>Pin(3&amp;4):</b> Clear CMOS <b>Pin(5&amp;6):</b> ME Disable	6-Pin Block	2.0mm
JPCAS_80P	<b>Pin (1&amp;2):</b> SHORT_CASE OPEN <b>Pin(3&amp;4):</b> SHORT_80 PORT	4-Pin Block	2.0mm
JPCOM1	COM1 Pin9 Function Select	4-Pin Block	2.0mm
JPCOM2	FP_COM2 Pin9 Function Select	4-Pin Block	2.0mm
M2B_PWR	M.2 B-key Power Select	3-Pin Block	2.0mm
M2E_PWR	M.2 E-key Power Select	3-Pin Block	2.0mm
M2M_PWR	M.2 M-key Power Select	3-Pin Block	2.0mm

# Chapter 2 Hardware Installation

## 2-1 Jumper Setting

**AT\_MODE (3-pin): ATX Mode/AT Mode Select** *Pitch=2.0mm*

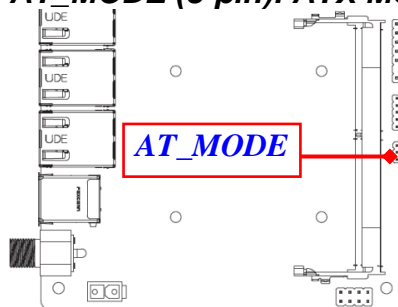

1-2 Closed: ATX Mode Selected;



2-3 Closed: AT Mode Selected.

---

**\*ATX Mode Selected:** Press power button to power on after power input ready;  
**AT Mode Selected:** Directly power on as power input ready.

**Pin (1-2) of JBAT (6-pin): Clear RTC Pitch=2.0mm**

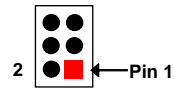
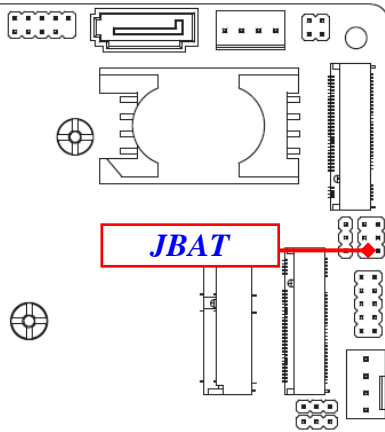

1-2 Open: Normal(Default);

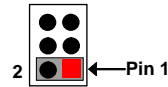

1-2 Closed: Clear RTC.

**Pin (3-4) of JBAT (6-pin): Clear CMOS Pitch=2.0mm**

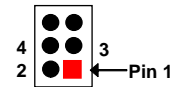
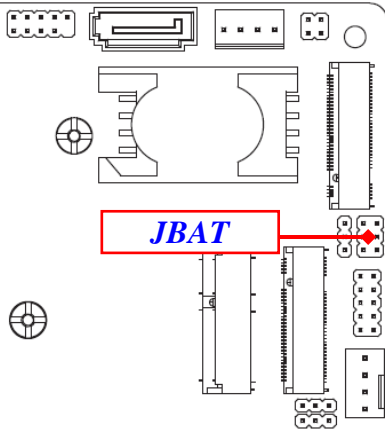

3-4 Open: Normal(Default);

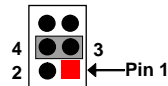

3-4 Closed: Clear CMOS.

---

---

**Pin (5-6) of JBAT (6-pin): ME Disable *Pitch=2.0mm***

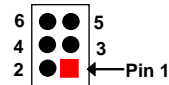
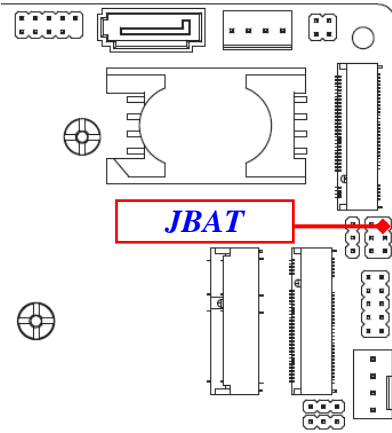

5-6 Open: Normal(Default);

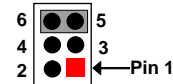

5-6 Closed: ME Disable.

**Pin (1-2) of JPCAS\_80P (4-pin): SHORT\_CASE OPEN *Pitch=2.0mm***

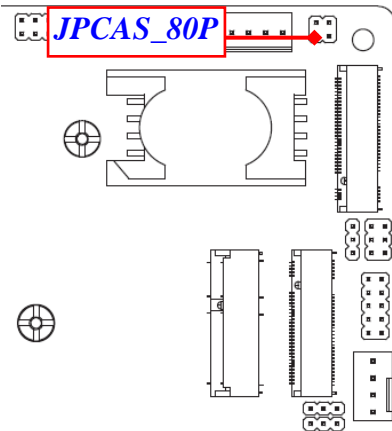

1-2 Open: Normal(Default);

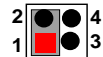

1-2 SHORT:CASE OPEN

**PIN (3-4) of JPCAS\_80P (4-pin): SHORT\_80 PORT Pitch=2.0mm**

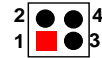
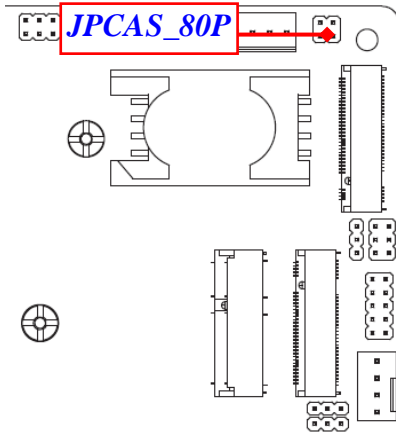

**3-4 Open: Normal(Default);**



**3-4 SHORT:80 PORT**

**JPCOM1 (4-pin) :COM1 Pin9 Function Select Pitch=2.0mm**

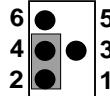
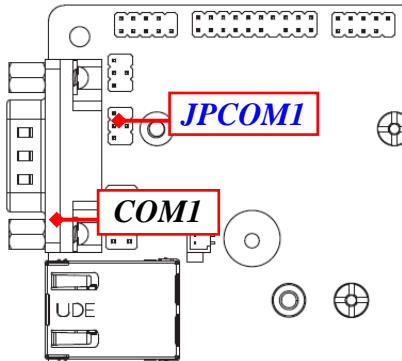

**2-4 Closed:  
RI=RS232**

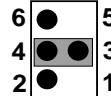

**3-4 Closed:  
RI=5V**

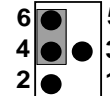

**4-6 Closed:  
RI=12V**

---

---

**JPCOM2 (4-pin) :FP\_COM2 Pin9 Function Select *Pitch=2.0mm***

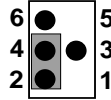
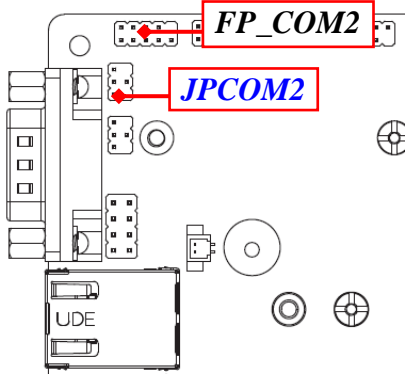

2-4 Closed:  
RI=RS232

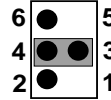

3-4 Closed:  
RI=5V

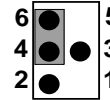

4-6 Closed:  
RI=12V

**M2B\_PWR (3-pin): M.2 B-key Power Select *Pitch=2.0mm***

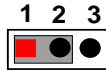
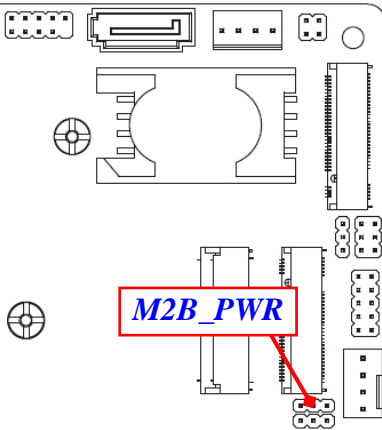

1-2 Closed:  
VCC= VCC3

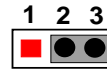

2-3 Closed:  
VCC= 3VSB



---

---

**M2E\_PWR (3-pin): M.2 E-key Power Select Pitch=2.0mm**

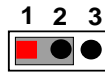
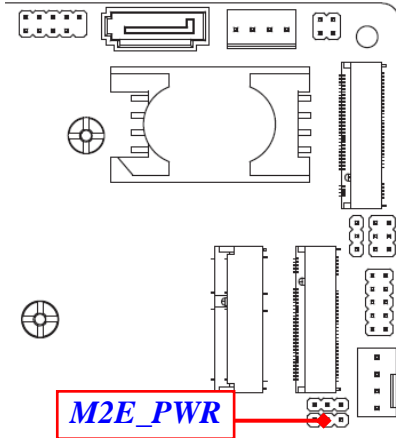

1-2 Closed:  
VCC= VCC3

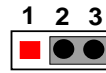

2-3 Closed:  
VCC= 3VSB

**M2M\_PWR (3-pin): M.2 M-key Power Select Pitch=2.0mm**

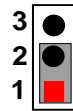
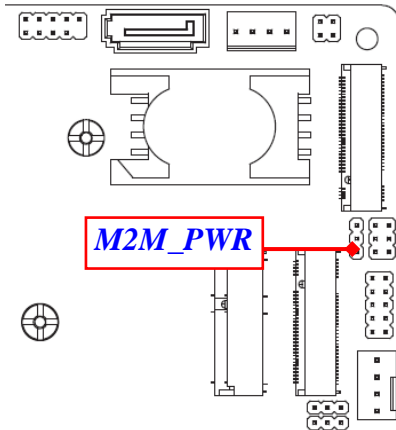

1-2 Closed:  
VCC= VCC3

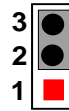

2-3 Closed:  
VCC= 3VSB

---





---

## 2-2 Connectors and Headers

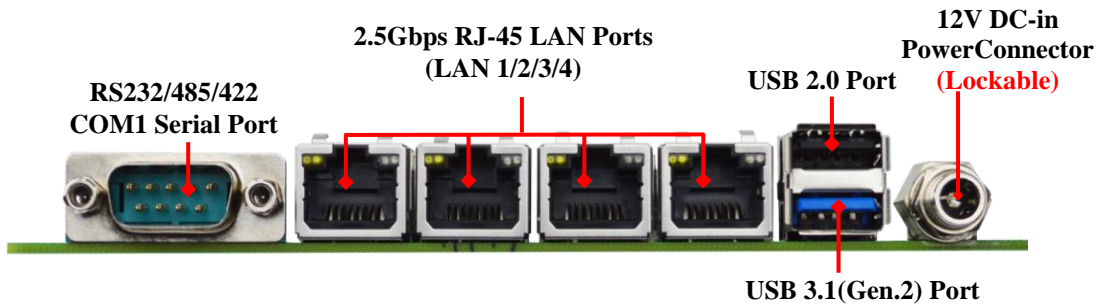
### 2-2-1 Connectors

#### (1) Rear I/O Connectors



<i>Icon</i>	<i>Name</i>	<i>Function</i>
	<b>12V DC-in Power Connector (Lockable)</b>	For user to connect compatible power adapter to provide power supply for the system.
	<b>USB 2.0 Port</b>	To connect USB keyboard, mouse or other devices compatible with USB specification.
	<b>USB 3.1(Gen.2) Port</b>	To connect USB keyboard, mouse or other devices compatible with USB specification. USB 3.1(Gen.2) ports supports up to 10Gbps data transfer rate.
	<b>2.5Gbps RJ-45 LAN Port</b>	This connector is standard 2.5Gbps RJ-45 LAN jack for Network connection. ( <b>*Note: 2.5Gbps is only supported with CAT 5e UTP cable).</b>

	<b>RS232/485/422 Serial Port</b>	Mainly for user to connect external MODEM or other devices that supports Serial Communications Interface.
---	----------------------------------	---

## (2) ATXPWR (2-pin Block): Internal 12V DC-in Power Connector

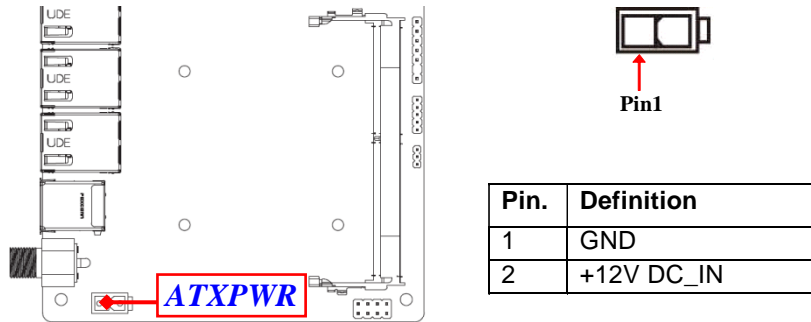

## (3) SATA1 (7-pin): SATAIII Port Connector

SATA1 is a high-speed SATAIII port that supports 6Gb/s transfer rate.

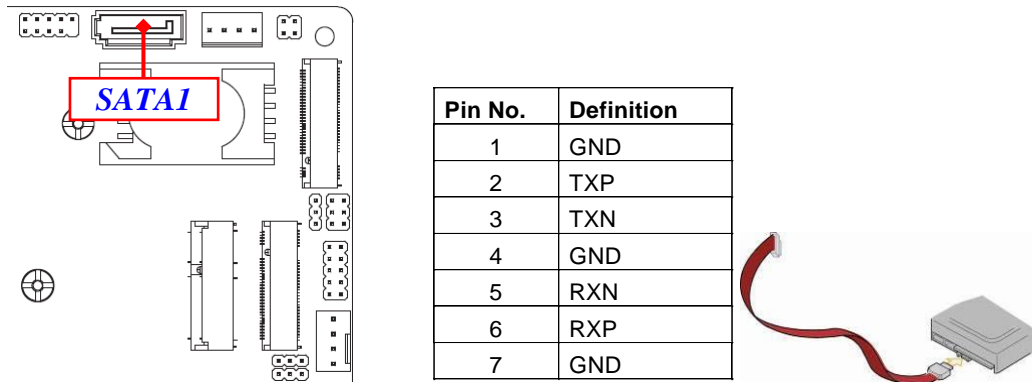

---

---

**(4) For 2.5Gbps RJ-45 LAN port:**

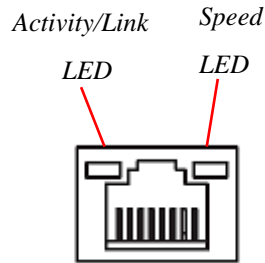

<b>Activity/Link LED</b>	
Status	Description
Off	No Link
Blinking	Data Activity
On	Link

<b>Speed LED</b>	
Status	Description
Off	10Mbps connection
Orange	1000Mbps connection
Green	2.5Gbps connection

\* **Note:** 2.5Gbps high-speed transmission rate is **only** supported over **CAT 5e UTP cable**

**(5) SATAPWR (4-pin): SATA HDD Power-Out Connector**

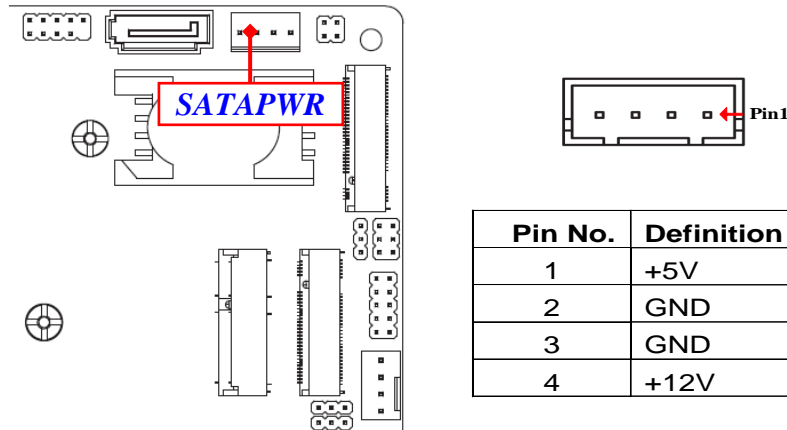

Pin No.	Definition
1	+5V
2	GND
3	GND
4	+12V

**Warning:** Make sure that Pin-1 of compatible SATA Power connector is inserted into corresponding Pin-1 of SATAPWR to avoid possible damage to the board and hard disk driver!

---

---

**(6) CPUFAN (4-pin): CPU FAN Connector**

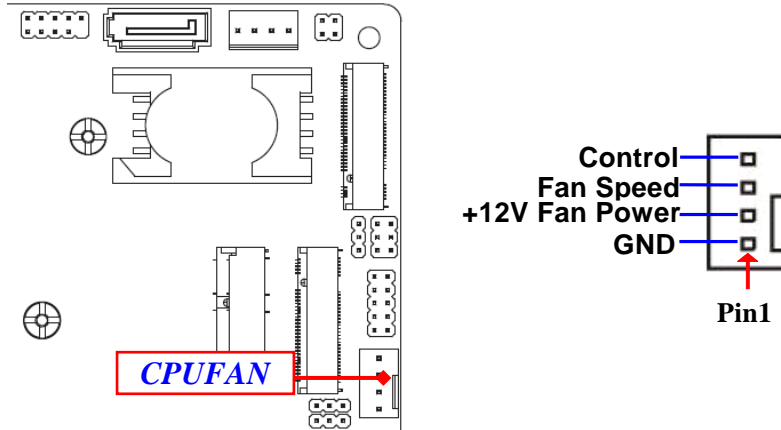

**(7) BATCON (2-pin): Battery Connector**

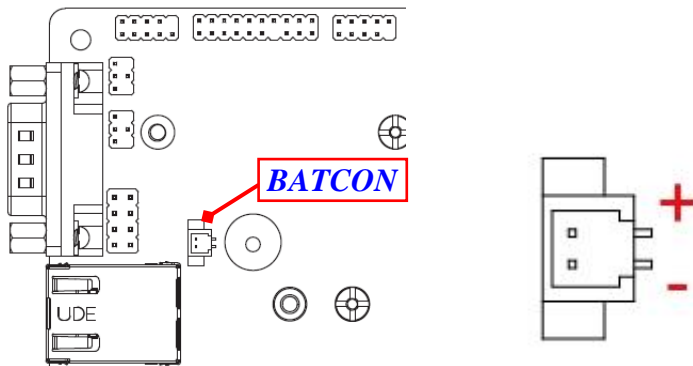

---

---

## 2-2-2 Headers

(1) JW\_FP (8-pin): Front Panel Header *Pitch=2.54mm*

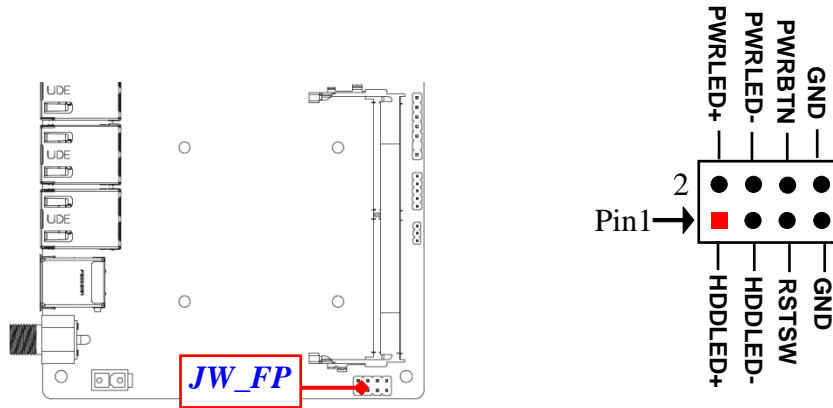

(2) SMBUS (5-pin): SM BUS Header *Pitch=2.0mm*

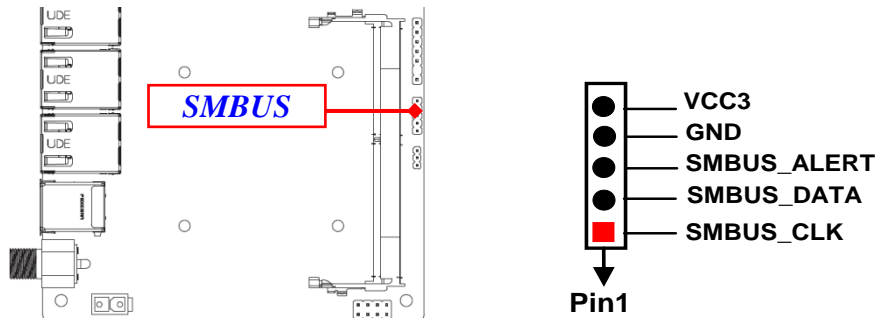

---

---

(3) PS2KBMS (6-pin): PS/2 Keyboard & Mouse Header *Pitch=2.54mm*

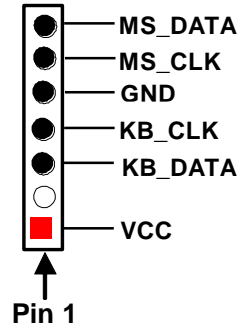
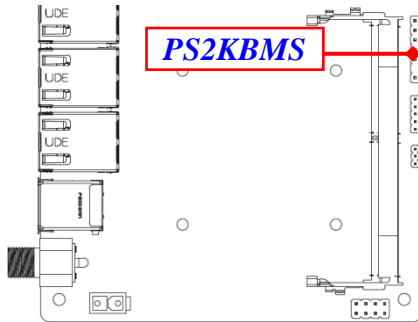

(4) GPIO (10-pin): GPIO Header *Pitch=2.0mm*

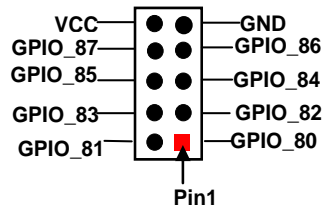
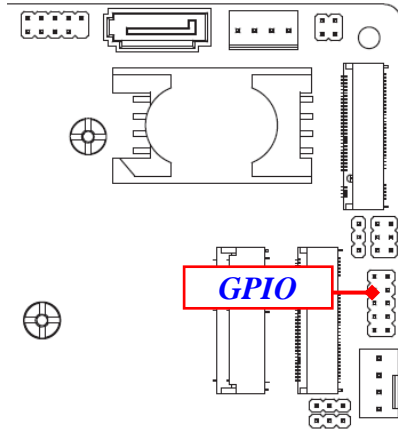

(5) FP\_USB21 (9-pin): USB 2.0 Port Header *Pitch=2.0mm*

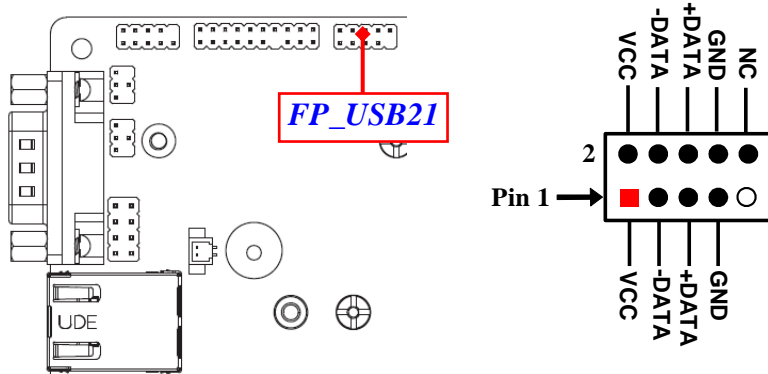

(6) HDMI1 (19-pin): HDMI Port Header *Pitch=2.0mm*

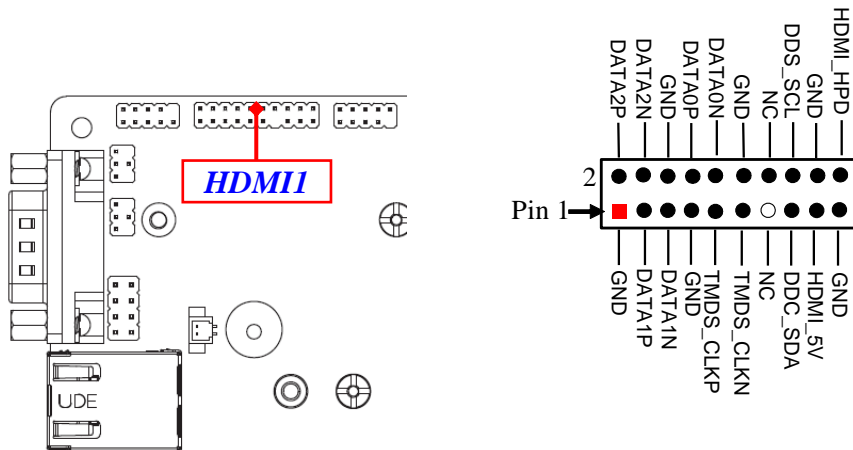



(7) FP\_COM2 (9-pin): Serial Port Header (support RS232/422/485)

*Pitch=2.0mm*

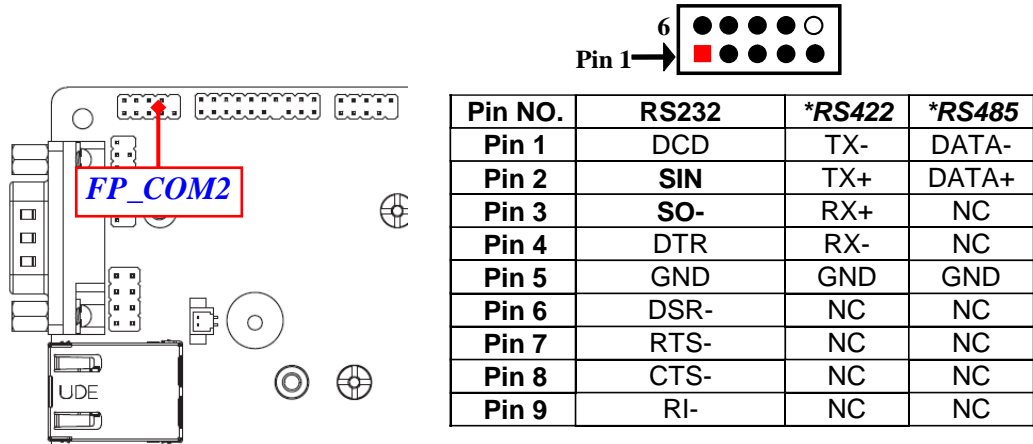

(8) LAN\_LED (8-pin): LAN Activity LED Header *Pitch=2.54mm*

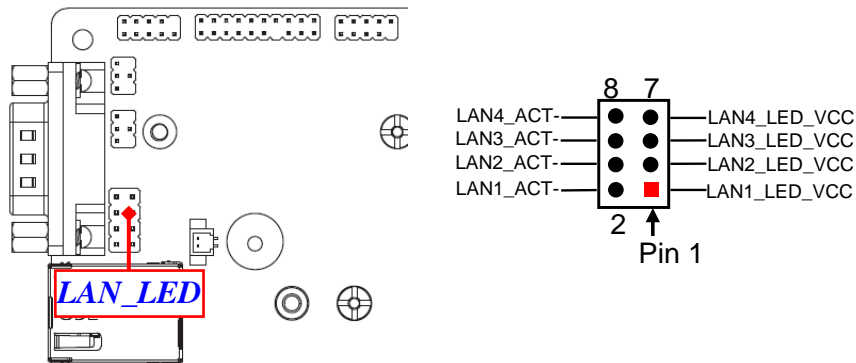

---

---

## 2-2-3 Maximum Voltage & Current Limit

Below is a list of maximum voltage & Current Limit specification for motherboard interface (including but not limited to slots, connectors, wafers and headers) for setup reference:

Location	Function	Working Voltage	Current Support
USB31	USB2.0/USB3.1(Gen.2)	5V	1.5A
SATAPWR	SATA 4Pin Power	5V	1A
CPUFAN	CPU FAN	5V	0.5A
SMBUS	SMBUS	5V	0.3A
GPIO	GPIO Port	5V	1.5A
JW_FP	Front Panel	5V	1A
PS2KBMS	PS/2 Keyboard & Mouse	5V	0.5A
FP_USB21	USB2.0 x2	5V	1.5A
LAN_LED	LAN Activity LED	3.3V	0.3A
JPCOM1	COM1 Function Select	5V or 12V	0.5A
JPCOM2	FP_COM2 Function Select	5V or 12V	0.5A
M2E_PWR	M.2 E-key Power	3.3V	2A
M2M_PWR	M.2 M-key Power	3.3V	2A
M2B_PWR	M.2 B-key Power	3.3V	2A

---

---

## Chapter 3

# Introducing BIOS

**Notice!** The BIOS options in this manual are for reference only. Different configurations may lead to difference in BIOS screen and BIOS screens in manuals are usually the first BIOS version when the board is released and may be different from your purchased motherboard. Users are welcome to download the latest BIOS version form our official website.

The BIOS is a program located on a Flash Memory on the motherboard. This program is a bridge between motherboard and operating system. When you start the computer, the BIOS program will gain control. The BIOS first operates an auto-diagnostic test called POST (power on self test) for all the necessary hardware, it detects the entire hardware device and configures the parameters of the hardware synchronization. Only when these tasks are completed done it gives up control of the computer to operating system (OS). Since the BIOS is the only channel for hardware and software to communicate, it is the key factor for system stability, and in ensuring that your system performance as its best.

### 3-1 Entering Setup

Power on the computer and by pressing <Del> immediately allows you to enter Setup. If the message disappears before your respond and you still wish to enter Setup, restart the system to try again by turning it OFF then ON or pressing the “RESET” button on the system case. You may also restart by simultaneously pressing <Ctrl>, <Alt> and <Delete> keys. If you do not press the keys at the correct time and the system does not boot, an error message will be displayed and you will again be asked to

Press **<Del>** to enter Setup; press **< F7>** to enter pop-up Boot menu.

```

Please select boot device:
UEFI: Built-in EFI Shell
Enter Setup

↑ and ↓ to move selection
ENTER to select boot device
ESC to boot using defaults

```

### 3-2 BIOS Menu Screen

The following diagram show a general BIOS menu screen:

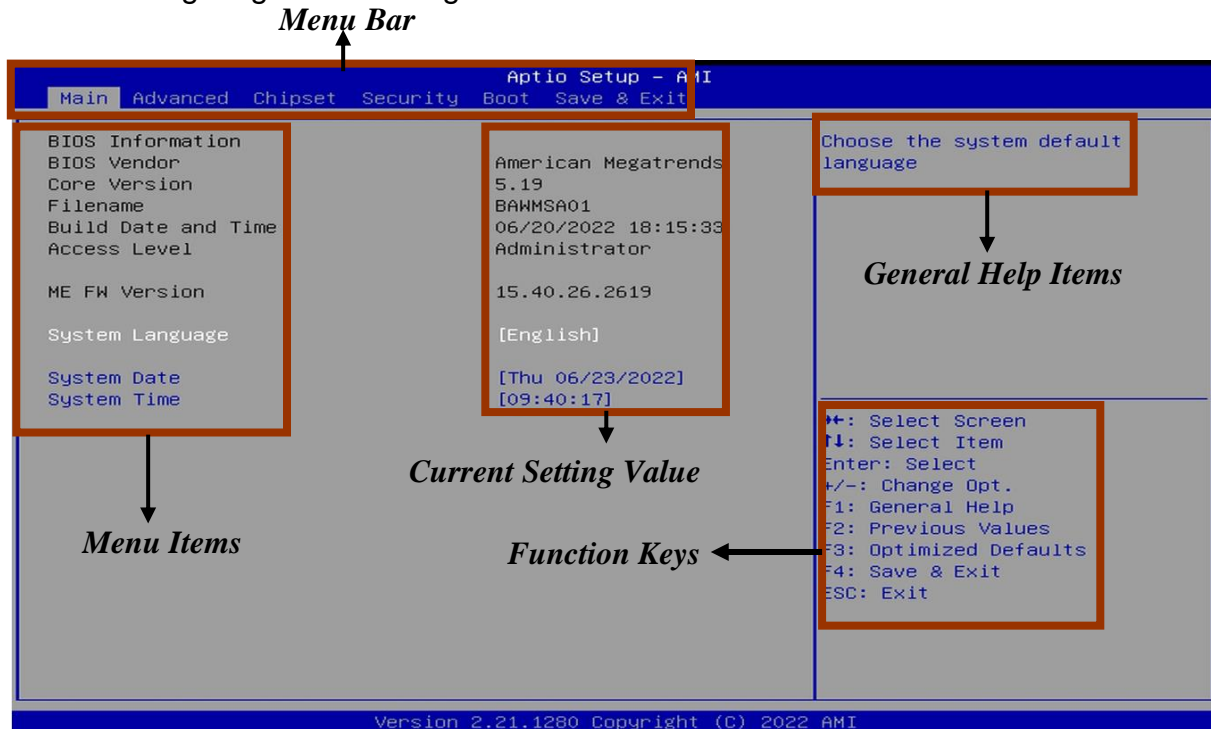

---

---

## 3-3 Function Keys

In the above BIOS Setup main menu of, you can see several options. We will explain these options step by step in the following pages of this chapter, but let us first see a short description of the function keys you may use here:

- Press ←→ (left, right) to select screen;
- Press ↑↓ (up, down) to choose, in the main menu, the option you want to confirm or to modify.
- Press <Enter> to select.
- Press <+>/<-> keys when you want to modify the BIOS parameters for the active option.
- [F1]: General help.
- [F2]: Previous value.
- [F3]: Optimized defaults.
- [F4]: Save & Exit.
- [F7]: To enter pop-up boot menu to select boot device.
- Press <Esc> to quit the BIOS Setup.

## 3-4 Getting Help

### Main Menu

The on-line description of the highlighted setup function is displayed at the top right corner the screen.

### Status Page Setup Menu/Option Page Setup Menu

Press [F1] to pop up a small help window that describes the appropriate keys to use and the possible selections for the highlighted item. To exit the Help Window, press <Esc>.

## 3-5 Menu Bars

There are six menu bars on top of BIOS screen:

---

<b>Main</b>	To change system basic configuration
<b>Advanced</b>	To change system advanced configuration
<b>Chipset</b>	To change chipset configuration
<b>Security</b>	Password settings
<b>Boot</b>	To change boot settings
<b>Save &amp; Exit</b>	Save setting, loading and exit options.

User can press the right or left arrow key on the keyboard to switch from menu bar. The selected one is highlighted.

### 3-6 Main Menu

Main menu screen includes some basic system information. Highlight the item and then use the <+> or <-> and numerical keyboard keys to select the value you want in each item.

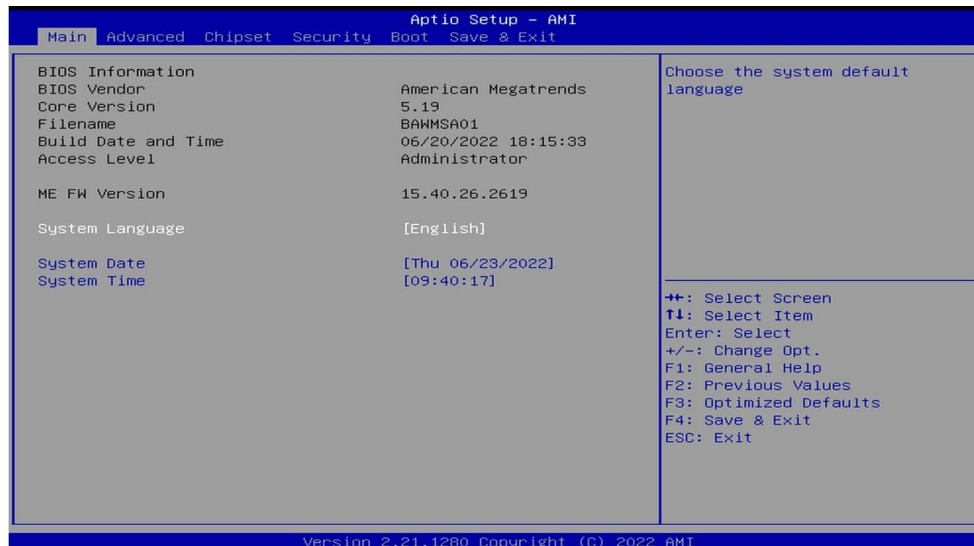

#### System Date

Set the date. Please use [Tab] to switch between data elements.

---

## System Time

Set the time. Please use [Tab] to switch between time elements.

## 3-7 Advanced Menu

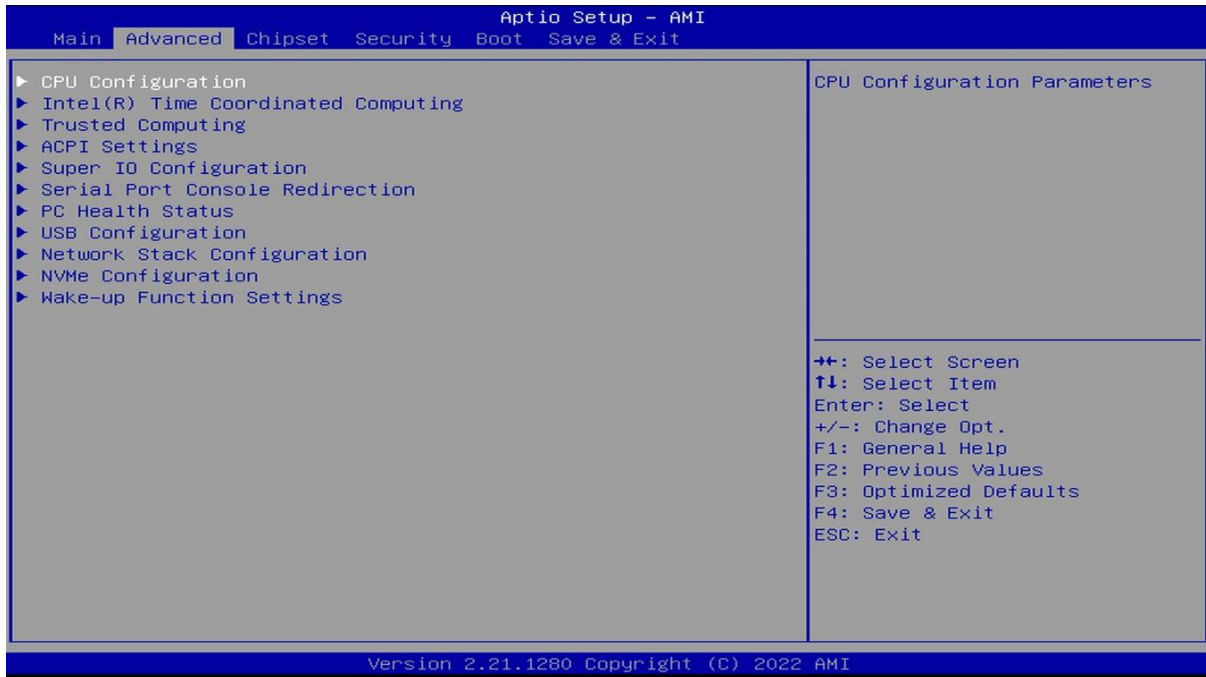

### ▶ CPU Configuration

Press [Enter] to make settings for the following items:

#### **Boot Performance Mode**

Use this item to select the performance state that the BIOS will set starting from reset vector.

The optional settings: [Max Battery]; [Max Non-Turbo Performance]; [Turbo Performance].

---

---

---

### **Intel(R) SpeedStep(tm)**

Use this item to allow more than two frequency ranges to be supported.  
The optional settings: [Disabled]; [Enabled].

*When set as [Enabled], the following item shall appear:*

#### **Turbo Mode**

Use this item to enable or disable processor Turbo Mode (requires EMTTM enabled too) AUTO means enabled.

The optional settings: [Disabled]; [Enabled].

#### **C states**

Use this item to enable or disable CPU Power Management. Allows CPU to go to C states when it's not 100% utilized.

The optional settings: [Disabled]; [Enabled]

*When set as [Enabled], the following item shall appear:*

#### **Enhanced C-states**

Use this item to enable or disable C1E. When enabled, CPU will switch to minimum speed when all cores enter C-State.

The optional settings: [Disabled]; [Enabled]

#### **Package C State Limit**

Use this item to maximum Package C State Limit Setting. CPU Default: Leaves to Factory default value. Auto: Initializes to deepest available package C State

The optional settings: [C0/C1]; [C2]; [C3]; [C6]; [C7]; [C7S]; [C8]; [C9]; [C10]; [CPU Default]; [Auto]

#### **Power Limit 1 Override**

Use this item to enable or disable Power Limit 1 override, If this option is disabled, BIOS WILL program the default values for power Limit 1 and Power Limit 1 Time Window.

The optional settings: [Disabled]; [Enabled]



---

---

*When set as [Enabled], the following item shall appear:*

### **Power Limit 1**

Use this item to power Limit 1 in Milli watts. BIOS will round to the nearest 1/8W when programming. 0=no custom override. 12.50W, enter 12500. Overclocking SKU: Value must be between Max and Min Power Limits (specified by PACKAGE\_POWER\_SKU\_MSR). Other SKUs: This value must be between Min Power Limit and TDP Limit. If value is 0, BIOS will program TDP value

### **Power Limit 1 Time Window**

Use this item to power Limit 1 Time Window value in seconds. The value may vary from 0 to 128. 0=default value (28 sec for Mobile and 8 sec for desktop). Defines time Window which TDP value should be maintained.

The optional settings: [0]; [1]; [2]; [3]; [4]; [5]; [6]; [7]; [8]; [10]; [12]; [14]; [16]; [20]; [24]; [28]; [32]; [40]; [48]; [56]; [64]; [80]; [96]; [112]; [128]

### **Power Limit 2 Override**

Use this item to enable/disable power Limit 2 override. If this option is disabled, BIOS will program the default values for Power Limit 2.

The optional settings: [Disabled]; [Enabled].

When set as [Enabled], user can make further settings in the following items:

### **Power Limit 2**

Use this item to power Limit 2 value in Milli watts. BIOS will round to the nearest 1/8W when programming. If the value is 0, BIOS will program this value as 1.25\*TDP. For 12.50W, enter 12500. Processor applies control policies such that the package power does not exceed this limit.

### ▶ **Intel(R) Time Coordinated Computing**

Use this item to Intel(R) Time Coordinated Computing (Intel(R) TCC) options

Press [Enter] to make settings for the following sub-items:

### **Intel(R) TCC Mode**

---

---

Use this item to enable or disable Intel(R) TCC mode. when enabled, this will modify system settings to improve real-time performance. The full list of settings and their current state are displayed below when Intel(R) TCC mode is enabled  
The optional settings: [Disabled]; [Enabled].

When set as [Enabled], user can make further settings in the following items:

### **Intel(R) TCC Authentication**

Use this item to enabled/disable authentication of Intel(R) TCC configuration data.  
The optional settings: [Disabled]; [Enabled].

When set **Intel(R) TCC Mode** as [Disabled], user can make further settings in the following items:

### **IO Fabric Low Latency**

Use this item to enabled or disable IO Fabric Low Latency. This will turn off some power management in the PCH IO fabrics. This option provides the most aggressive IO Fabric performance setting. S3 state is NOT supported

The optional settings: [Disabled]; [Enabled].

### **GT CLOS**

Use this item to enabled or disable Graphics Technology(GT) Class of Service. Enable will reduce Gfx LLC allocation to minimize impact of Gfx workload on LLC.  
The optional settings: [Disabled]; [Enabled].

### ▶ **Trusted Computing**

Press [Enter] to view current status information, or make settings in '**Security Device Support**'.

#### **Configuration**

### **Security Device Support**

Use this item to enable or disable BIOS support for security device. O.S. will not show Security Device. TCG EFI protocol and INT1A interface will not be available.  
The optional settings: [Disabled]; [Enabled].

*When set as [Enabled], the following item shall appear:*

---

---

**Active PCR Banks**

**Available PCR Banks**

**SHA-1 PCR Bank**

Use this item to enable or disable SHA-1 PCR Bank.

The optional settings: [Disabled]; [Enabled].

**SHA256 PCR Bank**

Use this item to enable or disable SHA256 PCR Bank.

The optional settings: [Disabled]; [Enabled].

**SHA384 PCR Bank**

Use this item to enable or disable SHA384 PCR Bank.

The optional settings: [Disabled]; [Enabled].

**SM3\_256 PCR Bank**

Use this item to enable or disable SM3\_256 PCR Bank.

The optional settings: [Disabled]; [Enabled].

**Pending Operation**

Use this item to schedule an operation for the security device

NOTE: Your computer will reboot during restart in order to change state of security device

The optional settings: [None]; [TPM Clear].

▶ **ACPI Settings**

Press [Enter] to make settings for the following sub-item:

**ACPI Settings**

**ACPI Sleep State**

Use this item to select the highest ACPI sleep state the system will enter when the suspend button is pressed.

The optional settings: [Suspend Disabled]; [S3 (Suspend to RAM)].

▶ **Super I/O Configuration**

Press [Enter] to make settings for the following sub-items:

**Super IO Configuration**

▶ **Serial Port 1 Configuration/ Serial Port 2 Configuration**

---

---

Press [Enter] to make settings for the following items:

### **Serial Port**

Use this item to enable or disable serial port (COM).

The optional settings: [Disabled]; [Enabled].

When set as [Enabled], user can make further settings in the following items:

### **Device Settings**

#### **Change Settings**

Use this item to select an optimal setting for super IO device. Changing setting may conflict with system resources.

The optional settings: [Auto]; [IO=3F8h; IRQ=4]; [IO=2F8h; IRQ=3]; [IO=3E8h; IRQ=4]; [IO=2E8h; IRQ=3].

#### **Transmission Mode Select**

The optional settings: [RS422]; [RS232]; [RS485]

#### **Mode Speed Select**

Use this item to RS232/RS422/RS485 Speed Select

The optional settings: [RS232/RS422/RS485=250Kbps]; [RS232=1Mbos, RS422/RS485=10Mbps]

#### **ERP Support**

The optional settings: [Disabled]; [Enabled].

This item should be set as [Disabled] if you wish to have all active wake-up functions.

#### **Case Open Detect**

Use this item to detect case has already open or not, show message in POST.

The optional settings: [Disabled]; [Enabled].

When set as [Enabled], system will detect if COPEN has been short or not (*refer to JPCAS\_80P jumper setting for Case Open Detection*); if Pin 1&2 of **JPCAS\_80P** are short, system will show Case Open Message during POST

#### **WatchDog Reset Timer**

Use this item to enable or disable WDT reset function.

---

---

---

The optional settings: [Disabled]; [Enabled].

When set as [Enabled], the following sub-items shall appear:

#### **WatchDog Reset Timer Value**

User can select a value in the range of [10] to [255] seconds when '**WatchDog Reset Timer Unit**' set as [Sec]; or in the range of [1] to [255] minutes when '**WatchDog Reset Timer Unit**' set as [Min].

#### **WatchDog Wake-up Timer**

This item support WDT wake-up while ERP function is set as [Enabled].

The optional settings: [Disabled]; [Enabled].

When set as [Enabled], the following sub-items shall appear:

#### **WatchDog Wake-up Timer Value**

The setting range is [10] ~ [4095] seconds, or [1] ~ [4095] minutes.

#### **WatchDog Wake-up Timer Unit**

The optional settings: [Sec.]; [Min.].

#### **ATX Power Emulate AT Power**

This item support Emulate AT power function, MB power On/Off control by power supply. Use needs to select 'AT or ATX Mode' on MB jumper at first (refer to AT\_MODE jumper setting Pin 1&2 of for ATX Mode & Pin 2&3 of AT Mode Select).

#### ▶ **Serial Port Console Redirection**

Press [Enter] to make settings for the following sub-items:

##### **COM1**

#### **Console Redirection**

The optional settings: [Disabled]; [Enabled]. When set as [Enabled], the following sub-items shall appear:

##### ▶ **Console Redirection Settings**

The settings specify how the host computer and the remote computer (which the user is using) will exchange data. Both computers should have the same or compatible settings.

Press [Enter] to make settings for the following items:

---

---

---

### **Terminal Type**

The optional settings: [VT100]; [VT100+]; [VT-UTF8]; [ANSI].

Emulation: [ANSI]: Extended ASCII char set; [VT100]: ASCII char set; [VT100+]: Extends VT100 to support color, function keys, etc.; [VT-UTF8]: Uses UTF8 encoding to map Unicode chars onto 1 or more bytes.

### **Bits per second**

Use this item to select serial port transmission speed. The speed must be matched on the other side. Long or noisy lines may require lower speeds.

The optional settings: [9600]; [19200]; [38400]; [57600]; [115200].

### **Data Bits**

The optional settings: [7]; [8].

### **Parity**

A parity bit can be sent with the data bits to detect some transmission errors.

The optional settings: [None]; [Even]; [Odd]; [Mark]; [Space].

[Even]: parity bit is 0 if the num of 1's in the data bits is even; [Odd]: parity bit is 0 if num of 1's in the data bits is odd; [Mark]: parity bit is always 1; [Space]: Parity bit is always 0; [Mark] and [Space] Parity do not allow for error detection.

### **Stop Bits**

Stop bits indicate the end of a serial data packet. (A start bit indicates the beginning). The standard setting is 1 stop bit. Communication with slow devices may require more than 1 stop bit.

The optional settings: [1]; [2].

### **Flow Control**

Flow control can prevent data loss from buffer overflow. When sending data, if the receiving buffers are full, a "stop" signal can be sent to stop the data flow. Once the buffers are empty, a "start" signal can be sent to re-start the flow. Hardware flow control uses two wires to send start/stop signals.

The optional settings: [None]; [Hardware RTS/CTS].

### **VT-UTF8 Combo Key Support**

Use this item to enable VT-UTF8 Combination Key Support for ANSI/VT100 terminals.

---

---

The optional settings: [Disabled]; [Enabled].

### **Recorder Mode**

With this mode enable only text will be sent. This is to capture Terminal data.

The optional settings: [Disabled]; [Enabled].

### **Resolution 100x31**

Use this item to enable or disable extended terminal resolution.

The optional settings: [Disabled]; [Enabled].

### **Legacy OS Redirection Resolution**

On Legacy OS, the Number of Rows and Columns supported redirection.

The optional settings: [80x24]; [80x25].

### **Putty KeyPad**

Use this item to select FunctionKey and KeyPad on Putty.

The optional settings: [VT100]; [LINUX]; [XTERMR6]; [SCO]; [ESCN]; [VT400].

### **Serial Port for Out-of-Band Management/**

### **Windows Emergency Management Services (EMS)**

#### **Console Redirection EMS**

The settings specify how the host computer and the remote computer (which the user is using) will exchange data. Both computers should have the same or compatible settings.

The optional settings: [Disabled]; [Enabled].

When set as [Enabled], user can make further settings in 'Console Redirection Settings':

#### ▶ **Console Redirection Settings**

The settings specify how the host computer and the remote computer (which the user is using) will exchange data. Both computers should have the same or compatible settings.

Press [Enter] to make settings for the following sub-items.

#### **Out-of-Band Mgmt Port**

#### **Terminal Type**

The optional settings: [VT100]; [VT100+]; [VT-UTF8]; [ANSI].

---

---

---

[VT-UTF8] is the preferred terminal type for out-of-band management. The next best choice is [VT100+] and then [VT100]. See above, in Console Redirection Settings page, for more help with Terminal Type/Emulation.

### **Bits per second**

Use this item to select serial port transmission speed. The speed must be matched on the other side. Long or noisy lines may require lower speeds.

The optional settings: [9600]; [19200]; [57600]; [115200].

### **Flow Control**

Flow control can prevent data loss from buffer overflow. When sending data, if the receiving buffers are full, a “stop” signal can be sent to stop the data flow. Once the buffers are empty, a “start” signal can be sent to re-start the flow. Hardware flow control uses two wires to send start/stop signals.

The optional settings: [None]; [Hardware RTS/CTS]; [Software Xon/Xoff].

### **Data Bits**

The default setting is: [8].

*\*This item may or may not show up, depending on different configuration.*

### **Parity**

The default setting is: [None].

*\*This item may or may not show up, depending on different configuration.*

### **Stop Bits**

The default setting is: [1].

*\*This item may or may not show up, depending on different configuration.*

## ▶ **PC Health Status**

Press [Enter] to view current hardware health status, set shutdown temperature, or make further settings in ‘**Smart Fan Configuration**’.

### ▶ **SmartFAN Configuration**

Press [Enter] to make settings for ‘**SmartFAN Configuration**’:

#### **CPUFAN Smart Mode**

The optional settings: [Disabled]; [Enabled].

When set as [Enabled], the following sub-items shall appear:



---

---

### **CPUFAN Full-Speed Temperature**

Use this item to set CPUFAN full speed temperature. Fan will run at full speed when above the preset temperature.

### **CPUFAN Full-Speed Duty**

Use this item to set CPUFAN full speed duty. Fan will run at full speed when above the pre-set duty.

### **CPUFAN Idle-Speed Temperature**

Use this item to set CPUFAN idle speed temperature. Fan will run at idle speed when below the pre-set temperature.

### **CPUFAN Idle-Speed Duty**

Use this item to set CPUFAN idle speed duty. Fan will run at idle speed when below the pre-set duty.

## ▶ **USB Configuration**

Press [Enter] to make settings for the following sub-item:

### **XHCI Hand-off**

This is a workaround for OSes without XHCI hand-off support. The XHCI ownership change should be claimed by XHCI driver

The optional settings: [Enabled]; [Disabled].

### **USB Mass Storage Driver Support**

Use this item to enable/disable USB Mass storage driver support

The optional settings: [Enabled]; [Disabled].

### **USB Transfer Time-out**

The time-out value for control bulk, and interrupt transfers.

The optional settings: [1 sec]; [5 sec]; [10 sec]; [20 sec].

### **Device Reset Time-out**

Use this item to USB mass storage device start unit command time-out

The optional settings: [10 sec]; [20 sec]; [30 sec]; [40 sec].

### **Device Power-up Delay**

Maximum time the device will take before it properly report itself to the host controller. 'Auto' uses default value: for a root port it is 100 ms, for a Hub port the delay is taken from Hub descriptor

---

---

The optional settings: [Auto]; [Manual]

When set as [Manual], the following sub-items shall appear:

**Device Power-up Delay in Seconds**

Use this item to delay range is 1..40 seconds in one second increments

▶ **Network Stack Configuration**

Press [Enter] to go to 'Network Stack' screen to make further settings.

**Network Stack**

The optional settings: [Enabled]; [Disabled].

When set as [Enabled], the following sub-items shall appear:

**Ipv4 PXE Support**

The optional settings: [Disabled]; [Enabled].

Use this item to enable Ipv4 PXE Boot Support. When set as [Disabled], Ipv4 boot optional will not be created.

**Ipv6 PXE Support**

The optional settings: [Disabled]; [Enabled].

Use this item to enable Ipv6 PXE Boot Support. When set as [Disabled], Ipv6 boot optional will not be created.

**PXE boot wait time**

Use this item to set wait time to press [ESC] key to abort the PXE boot.

**Media Detect Count**

Use this item to number of time the presence of media will be checked. Use either +/- or numeric keys to set the value

▶ **NVMe Configuration**

Press [Enter] to make settings for the following sub-items:

*\*Note: options only when NVMe device is available.*

▶ **Wake-up Function Settings**

Press [Enter] to make settings for the following sub-items:

**Wake-up System with Fixed Time**

Use this item to enable or disable system wake-up by RTC alarm.

The optional settings: [Disabled]; [Enabled].

When set as [Enabled], system will wake on the hour/min/sec specified.

---

---

---

### **Wake-up Hour**

Use this item to 0-23. For example, 3 for 3am and 15 for 3pm

### **Wake-up Minute**

Use this item to 0-59

### **Wake-up second**

Use this item to 0-59

### **Wake-up System with Dynamic Time**

Use this item to enable or disable system wake-up by RTC alarm.

The optional settings: [Disabled]; [Enabled].

When set as [Enabled], system will wake on the current time + increased minute(s).The settings range is from [1] ~ [60] minute(s).

### **Wake-up Time Increase**

Use this item to 1 to 60 minute(s)

### **PS2 KB/MS Wake-Up from S3-S5**

Use this item to PS2 KB/MS Wake-up is affected by ERP function in S4-S5.

Please disabled ERP before activating this function in S4-S5.

The optional settings: [Disabled]; [Enabled].

### **USB Power Gating S4-S5**

Use this item to USB Wake-up is affected by ERP function in S4. Please disable ERP before activating this function in S4.

The optional settings: [Disabled]; [Enabled].

### **PCIe Wake-up from S3-S5**

The optional settings: [Disabled]; [Enabled]

---

---

## 3-8 Chipset Menu

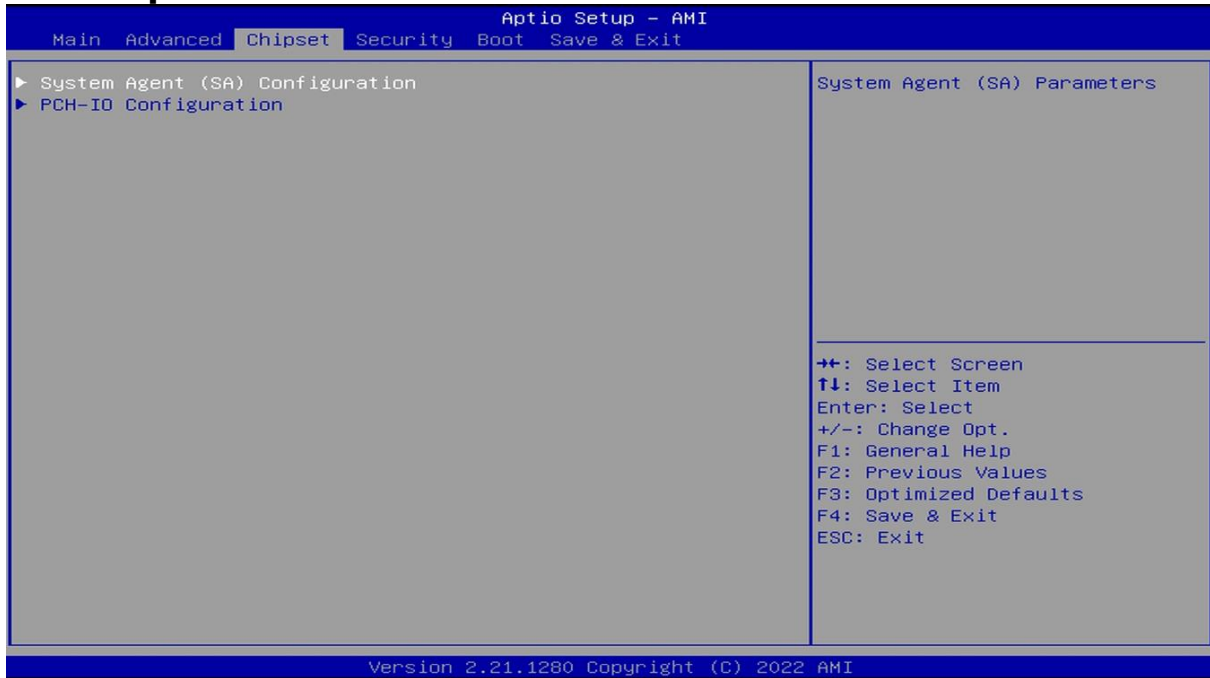

### ▶ System Agent(SA) Configuration

Press [Enter] to make settings for the following sub-items:

#### **GTT Size**

Use this item to select the GTT Size.

The optional settings: [2MB]; [4MB]; [8MB].

#### **DVMT Pre-Allocated**

Use this item to select DVMT 5.0 pre-allocated (fixed) graphics memory size used by the internal graphics device.

The optional settings: [0M]; [4M]; [8M]; [12M]; [16M]; [20M]; [24M]; [28M]; [32M]; [36M]; [40M]; [44M]; [48M]; [52M]; [56M]; [60M]; [64M]; [96M]; [128M]; [160M]

---

---

### **DVMT Total Gfx Mem**

Use this item to select DVMT 5.0 total graphics memory size used by the internal graphics device.

The optional settings: [128M]; [256M]; [MAX].

### **Total Memory**

#### ▶ **PCH-IO Configuration**

Press [Enter] to make further settings in south bridge parameters.

#### ▶ **PCI Express Configuration**

Press [Enter] to make further settings in south bridge parameters.

#### **Peer Memory Write Enable**

The optional settings: [Enabled]; [Disabled].

#### ▶ **SATA Configuration**

Press [Enter] to make settings for the following sub-items:

#### **SATA Controller**

Use this item to enable/disable SATA Device

When set as [Enabled], the following sub-items shall appear:

#### **SATA Mode Selection**

Use this item to determines how SATA controller(s) operate.

The optional settings: [AHCI]

#### **SATA Port**

#### **SATA Port**

The optional settings: [Enabled]; [Disabled].

#### **Hot Plug**

Use this item to designates this port as Hot Pluggable

The optional settings: [Enabled]; [Disabled].

#### **M.2**

#### **M.2**

The optional settings: [Enabled]; [Disabled].

#### **HD-Audio Support**

The optional settings: [Enabled]; [Disabled].

---

---

## SCS eMMC Support

The optional settings: [Enabled]; [Disabled].

## System State after Power Failure

Use this item to specify what state to go to when power is re-applied after a power failure

The optional settings: [Always On]; [Always Onff]; [Former State]

## PinCntrl Driver GPIO Scheme

Use this item to enable/disable PinCntrl Driver GPIO Scheme

The optional settings: [Enabled]; [Disabled]

## 3-9 Security Menu

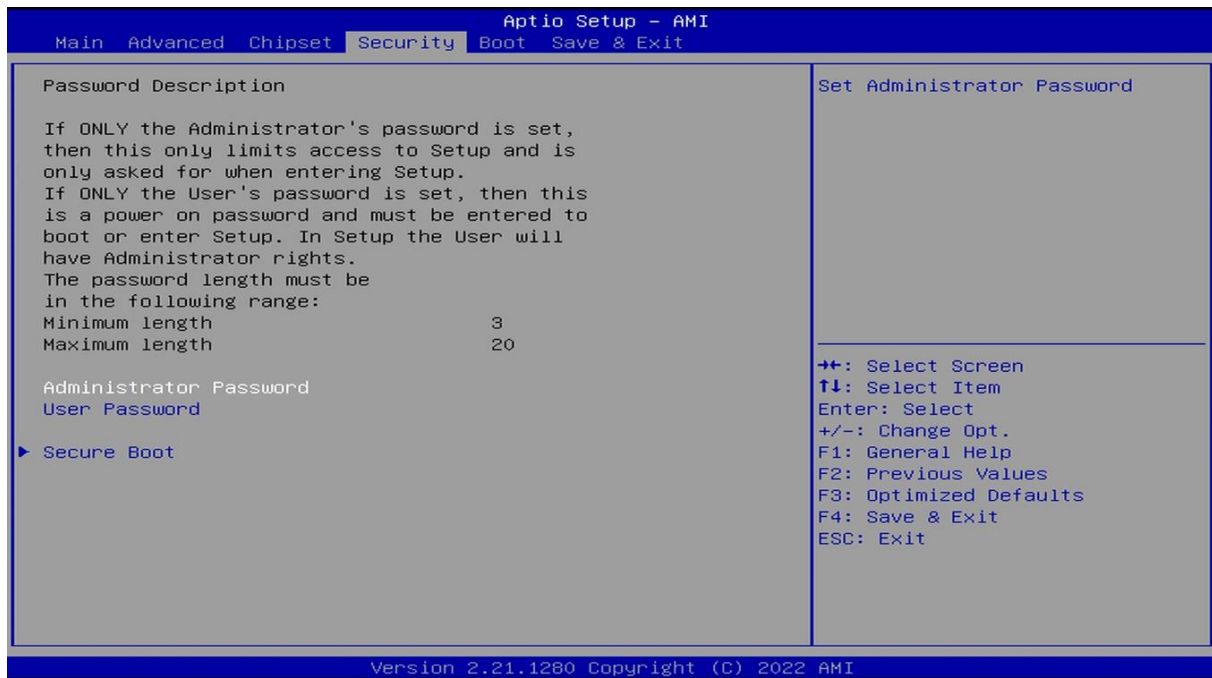

---

---

Security menu allow users to change administrator password and user password settings.

### **Administrator Password**

Press [Enter] to create new administrator password. Press again to confirm the new administrator password.

### **User Password**

Press [Enter] to create new user password. Press again to confirm the new user password.

#### ▶ **Secure Boot**

Press [Enter] to make customized secure settings:

#### **System Mode**

##### **Secure Boot**

Secure Boot feature is Active if Secure Boot is Enabled, Platform Key(PK) is enrolled and the System is in User mode. The mode change requires platform reset.

The optional settings: [Disabled]; [Enabled].

##### **Secure Boot Mode**

Set UEFI Secure Boot Mode to Standard mode or Custom mode. This change is effective after save. After reset, this mode will return to Standard mode.

In Custom mode, Secure Boot Policy variables can be configured by a physically present user without full authentication.

The optional settings: [Standard]; [Custom].

When set as [**Custom**], user can make further settings in the following items that show up:

#### ▶ **Restore Factory Keys**

Use this item to force system to User Mode, to install factory default Secure Boot key databases.

#### ▶ **Reset To Setup Mode**

Use this item to delete all Secure Boot key databases from NVRAM.

#### ▶ **Key Management**

---

---

This item enables expert users to modify Secure Boot Policy variables without full authentication, which includes the following items:

**Vendor Keys**

**Factory Key Provision**

This item is for user to install factory default Secure Boot keys after the platform reset and while the System is in Setup mode.

The optional settings: [Disabled]; [Enabled].

▶ **Restore Factory Keys**

Use this item to force system into User Mode. Install factory default Secure Boot key databases.

▶ **Reset To Setup Mode**

Use this item to delete all Secure Boot key databases from NVRAM.

▶ **Export Secure Boot variables**

Use this item to copy NVRAM content of Secure Boot variables to files in a root folder on a file system device.

▶ **Enroll Efi Image**

This item allows the image to run in Secure Boot mode.

Enroll SHA256 Hash certificate of a PE image into Authorized Signature Database (db).

**Device Guard Ready**

▶ **Remove 'UEFI CA' from DB**

▶ **Restore DB defaults**

Use this item to restore DB variable to factory defaults.

**Secure Boot variable/Size/Keys/Key Source**

▶ **Platform Key(PK)/Key Exchange Keys/Authorized Signatures/Forbidden Signatures/ Authorized TimeStamps/OsRecovery Signatures**

Use this item to enroll Factory Defaults or load certificates from a file:

1. Public Key Certificate:

a) EFI\_SIGNATURE\_LIST

b) EFI\_CERT\_X509 (DER)



- 
- c) EFI\_CERT\_RSA2048 (bin)
  - d) EFI\_CERT\_SHAXXX
  - 2. Authenticated UEFI Variable
  - 3. EFI PE/COFF Image (SHA256)
- Key Source: Factory, External, Mixed

## 3-10 Boot Menu

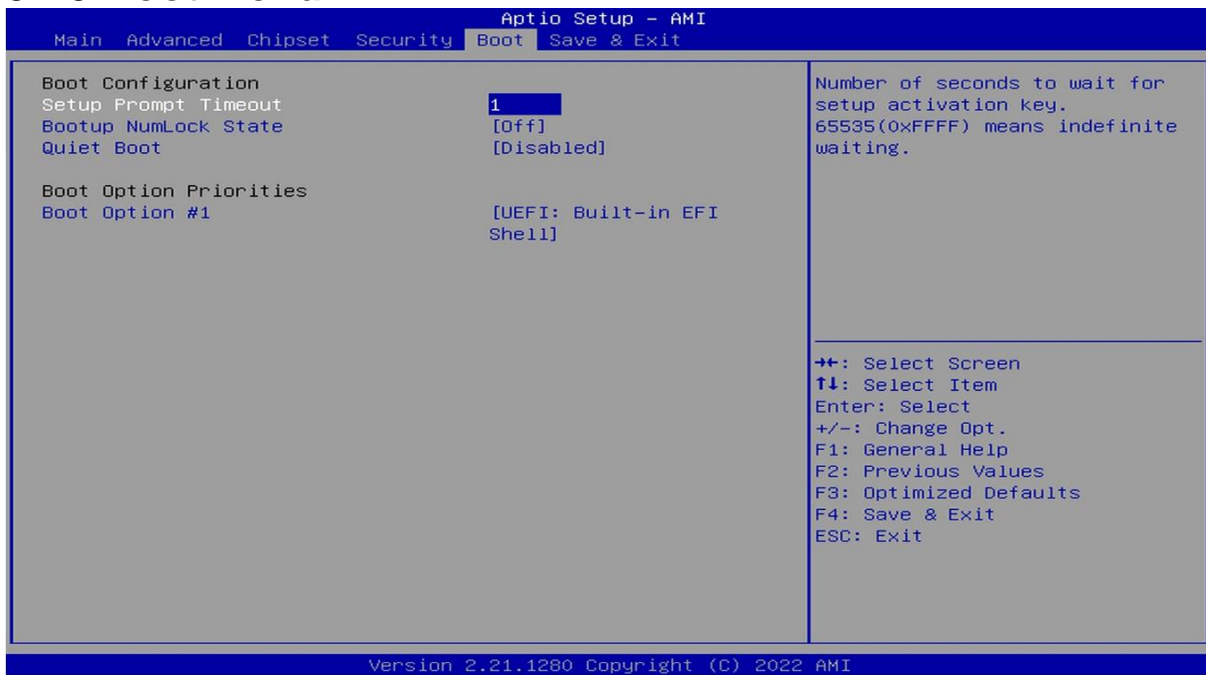

### Boot Configuration

#### Setup Prompt Timeout

Use this item to set number of seconds to wait for setup activation key.

#### Bootup Numlock State

---

Use this item to select keyboard numlock state.

The optional settings: [On]; [Off].

### **Quiet Boot**

The optional settings: [Disabled]; [Enabled].

### **Boot Option Priorities**

#### **Boot Option #1**

Use this item to decide system boot order from available options.

The optional settings: [UEFI: Bulit-in EFI Shell]; [Disabled].

## **3-11 Save & Exit Menu**

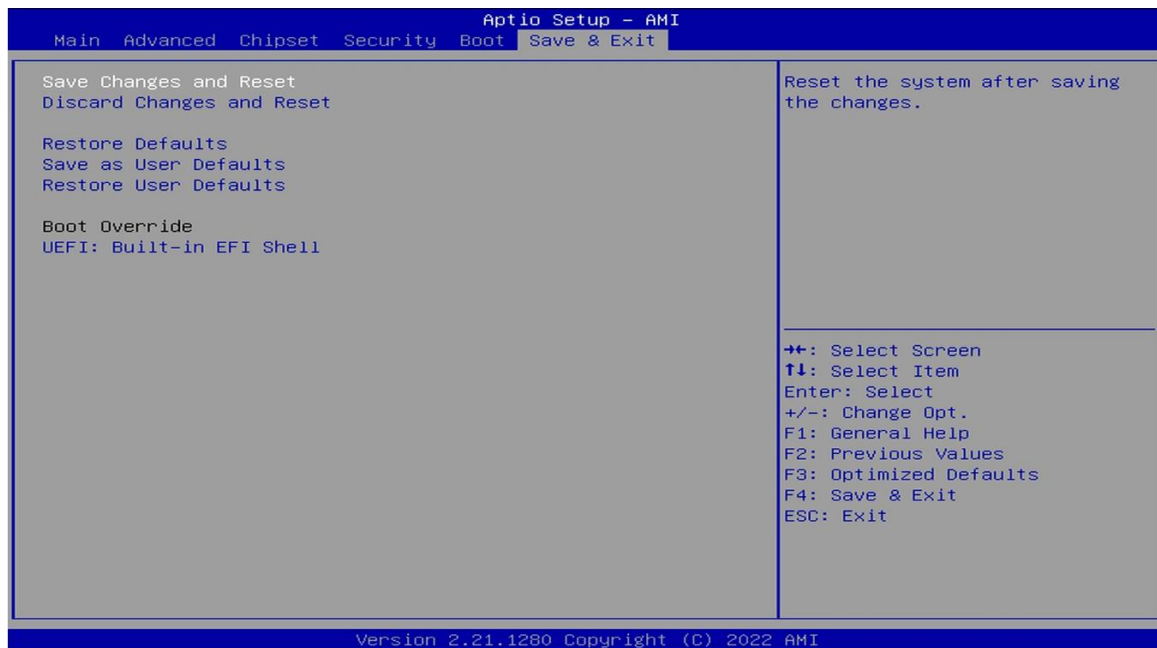

### **Save Changes and Reset**

This item allows user to reset the system after saving the changes.

---

---

---

### **Discard Changes and Reset**

This item allows user to reset the system without saving any changes.

### **Restore Defaults**

Use this item to restore /load default values for all the setup options.

### **Save as User Defaults**

Use this item to save the changes done so far as user defaults.

### **Restore User Defaults**

Use this item to restore the user defaults to all the setup options.

### **Boot Override**

#### **Boot Override**

#### **UEFI:Built-in EFI Shell**

Press this item to select the device as boot disk after save configuration and reset.