

ESP-01S RELAY MODULE

Remotely controllable relay module

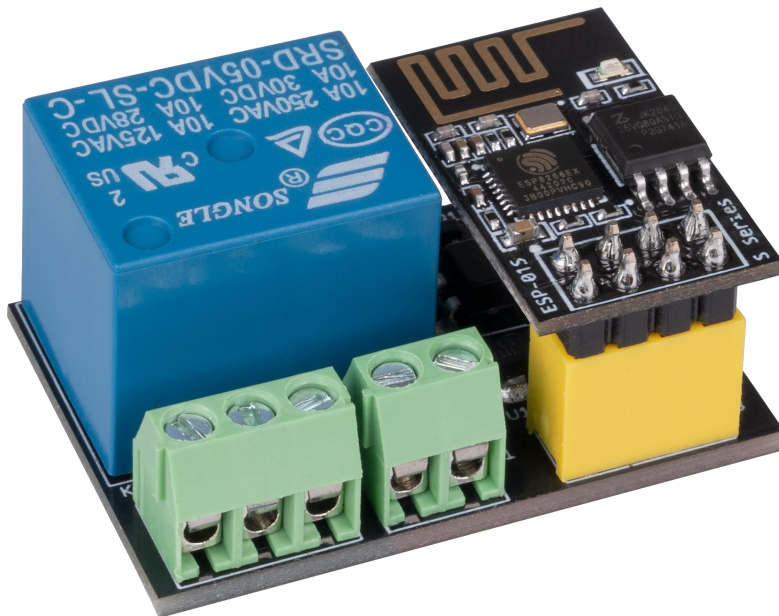

1. GENERAL INFORMATION

Dear customer,
thank you very much for choosing our product.
In following, we will introduce you to what to observe while starting up
and using this product.
Should you encounter any unexpected problems during use, please do
not hesitate to contact us.

2. PROGRAMMING THE ESP-01S RELAY MODULE

To use the ESP-01S relay module, you must first program the ESP-01S supplied on the product.

For this, we recommend programming the ESP-01S with the ESP8266 PROG from [JOY-IT](#).

First, the Arduino development environment must be prepared for use with the ESP8266.

To do this, the following URL is entered in the global settings of the program as an **additional board administrator URL**:

https://arduino.esp8266.com/stable/package_esp8266com_index.json

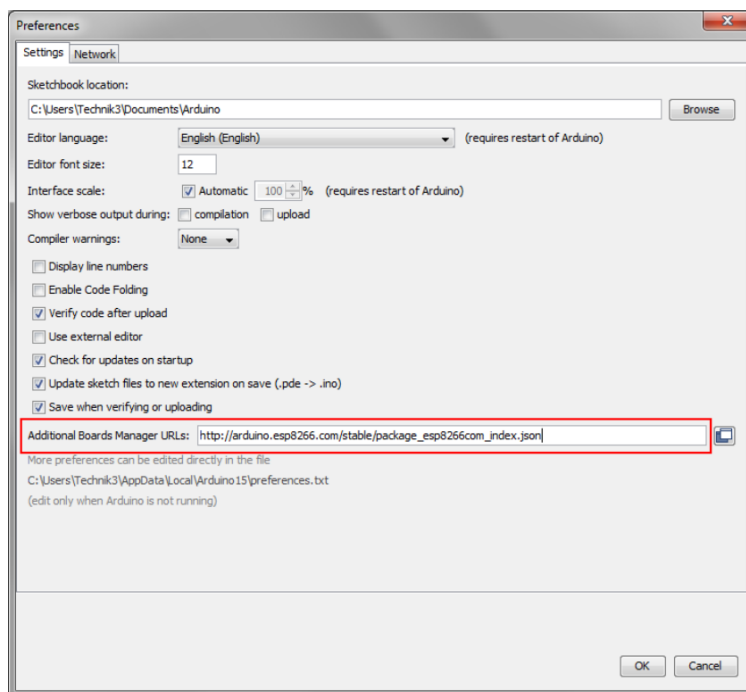
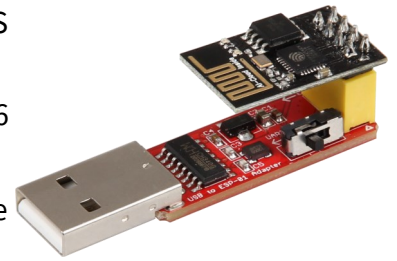

Next, an additional board library must be installed. Open the board manager and install the **ESP8266** library.

Please note that your Arduino development environment must be restarted if the board library is not displayed.

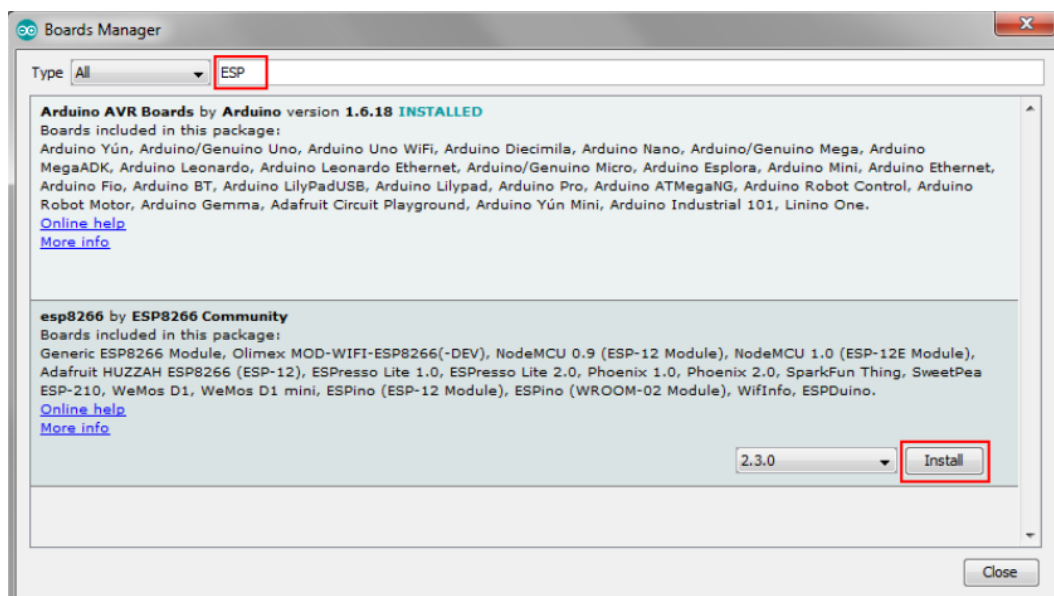

Once you have successfully installed the board, you can select the **Generic ESP8266 Module** from the list of available boards.

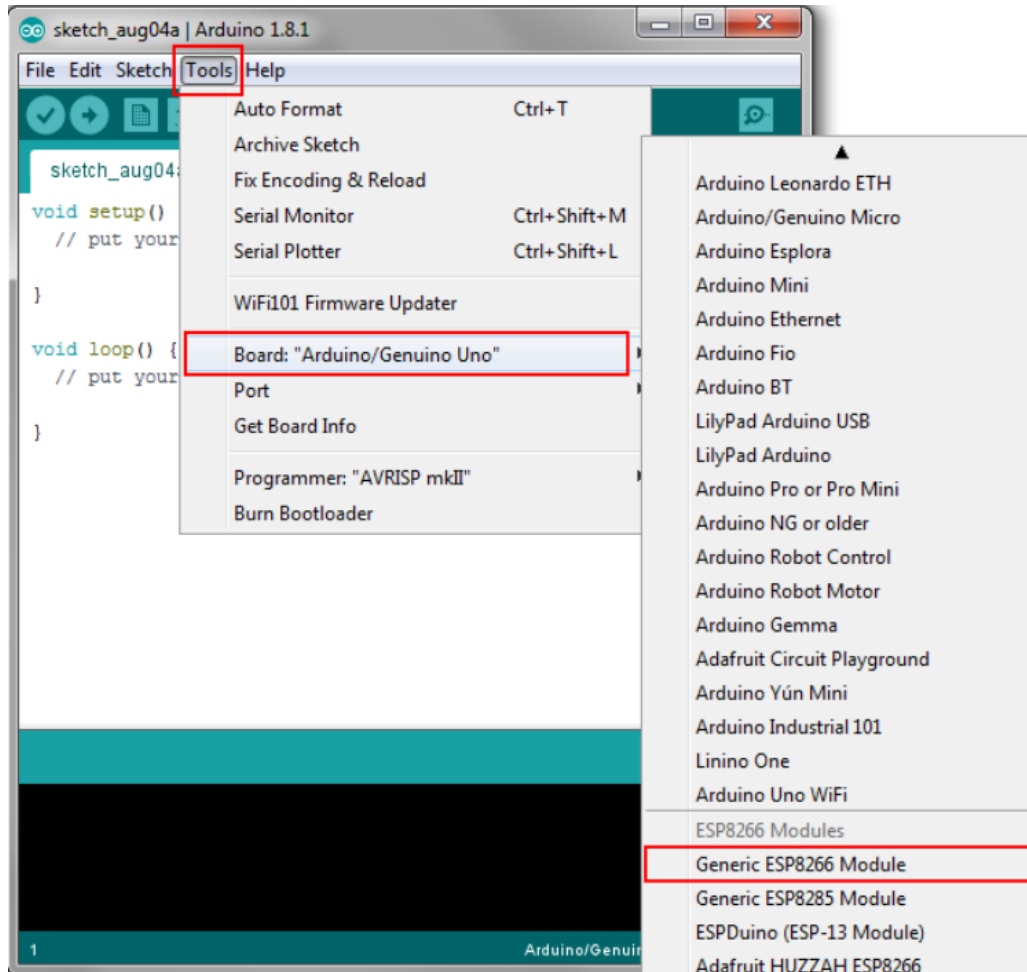

Your Arduino development environment is now prepared for the use with an ESP8266.

3. CODE EXAMPLE

Now you can simply copy the following code example into your Arduino IDE and upload it to your ESP-01S.

```
#include <ESP8266WiFi.h>

const char* ssid = "MeineWlanSSID"; // Enter your router or
WiFi SSID here
const char* password = "MeinWlanPasswort"; // Enter your rou-
ter or WiFi password here
#define RELAY 0 // connected to GPIO0
WiFiServer server(80);

void setup(){
  Serial.begin(115200); // must have the same baud rate as
the serial monitor

  pinMode(RELAY, OUTPUT);
  digitalWrite(RELAY, LOW);

  // Connect to the WiFi network
  Serial.println();
  Serial.println();
  Serial.print("Connecting to ");
  Serial.println(ssid);

  WiFi.begin(ssid, password);

  while (WiFi.status() != WL_CONNECTED){
    delay(500);
    Serial.print(".");
  }
  Serial.println("");
  Serial.println("WiFi connected");

  // Start the Server
  server.begin();
  Serial.println("Server started");

  // Output of the IP address
  Serial.print("Use this URL to connect: ");
  Serial.print("https://");
  Serial.print(WiFi.localIP());
  Serial.println("/");
}

void loop(){
  // Check whether a user has established a connection
  WiFiClient client = server.available();
  if (!client){
    return;
  }
  // Wait until the user sends data
  Serial.println("new client");
  while(!client.available()){
    delay(1);
  }
  // Reading the first line of the request
  String request = client.readStringUntil('\r');
  Serial.println(request);
  client.flush();
}
```

```

// Assignment of the request
int value = LOW;
if (request.indexOf("/RELAY=ON") != -1){
    Serial.println("RELAY=ON");
    digitalWrite(RELAY,LOW);
    value = LOW;
}
if (request.indexOf("/RELAY=OFF") != -1){
    Serial.println("RELAY=OFF");
    digitalWrite(RELAY,HIGH);
    value = HIGH;
}

// Return the answer
client.println("HTTP/1.1 200 OK");
client.println("Content-Type: text/html");
client.println(""); // this is necessary
client.println("<!DOCTYPE HTML>");
client.println("<html>");
client.println("<meta name='viewport' content='width=device
-width, initial-scale=1'>");
client.println("<head><title>ESP8266 RELAY Control</
title></head>");
client.println("<style>");
client.println("* {text-align: center; font-family: Conso-
las;}");
client.println("");
client.println(".container {position: absolute; top:
50%;}");
client.println("left: 50%; transform: translateX(-50%
translateY(-50%);}");
client.println("");
client.println("a {display: inline-block; width: 50px;}");
client.println("color: #FFFFFF; background-color:
#275C6B;");
client.println("margin-top: 15px; padding: 10px 20px;");
client.println("text-decoration: none; border-radius:
5px;");
client.println("font-weight: 800;}");
client.println("</style>");
client.println("<div class='container'>");
client.println("<div class='inner'>");
client.print("Relay is now: ");

if(value == HIGH){client.print("OFF");}
else{client.print("ON");}

client.println("<br>");
client.println("<a href=\"/RELAY=OFF\">OFF</a>");
client.println("<a href=\"/RELAY=ON\">ON</a>");
client.println("</div>");
client.println("</div>");
client.println("</html>");
Serial.println("");
}

```

After you have uploaded the code to your Esp-01S, you need to pull the ESP-01S programmer out of your PC and set the small switch on the side of PROG to UART so that you can see the serial output of the ESP-01S in your IDE. Once you have flipped the switch, you can put the programmer of your ESP-01S back into your PC and view the serial output of your ESP-01S to see if the connection to your WiFi was successful.

4. CONNECTION OF THE ESP-01S ON THE RELAY MODULE

After programming the ESP-01S, you can now unplug the ESP8266-PROG from your PC and remove the ESP-01S.

In the next step, you have to make sure that you plug your ESP-01S correctly on the relay module. In the following figure it is color-coded which pin of the ESP-01S belongs to which pin on the relay module.

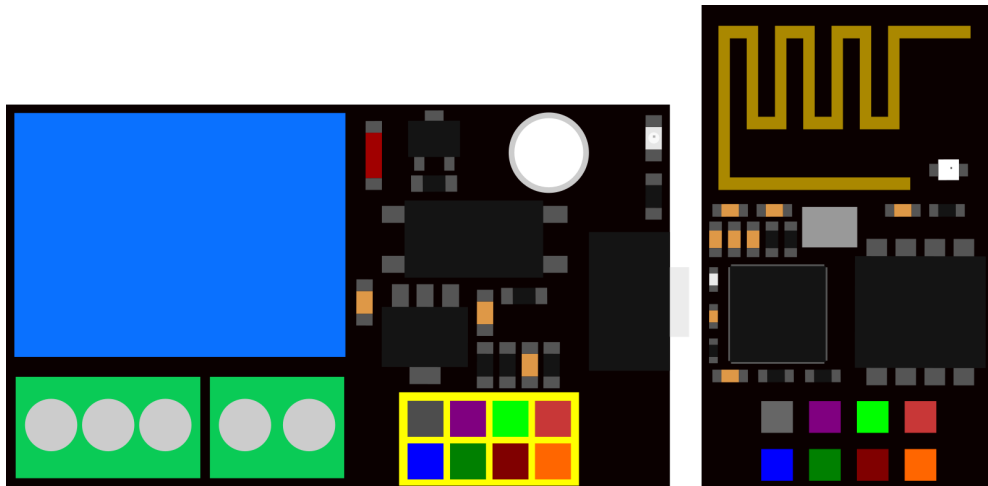

After plugging the ESP-01S into the relay module, you can now connect a supply voltage of 5 - 12 V. After that, you can go to the website by simply entering the IP address you saw in your serial output in your browser **(enter the IP address in your browser on a device that is in the same network as the ESP-01S)**.

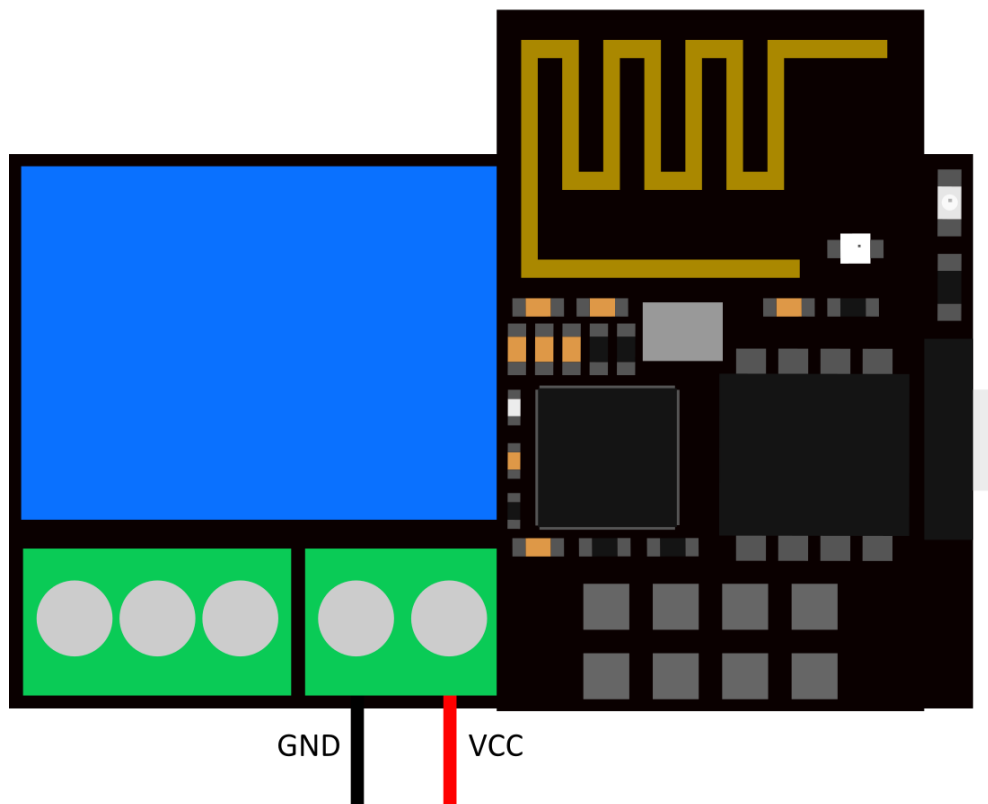

5. ADDITIONAL INFORMATION

Our information and take-back obligations according to the Electrical and Electronic Equipment Act (ElektroG)

Symbol on electrical and electronic equipment:



This crossed-out dustbin means that electrical and electronic appliances do not belong in the household waste. You must return the old appliances to a collection point.

Before handing over waste batteries and accumulators that are not enclosed by waste equipment must be separated from it.

Return options:

As an end user, you can return your old device (which essentially fulfils the same function as the new device purchased from us) free of charge for disposal when you purchase a new device.

Small appliances with no external dimensions greater than 25 cm can be disposed of in normal household quantities independently of the purchase of a new appliance.

Possibility of return at our company location during opening hours:

SIMAC Electronics GmbH, Pascalstr. 8, D-47506 Neukirchen-Vluyn, Germany

Possibility of return in your area:

We will send you a parcel stamp with which you can return the device to us free of charge. Please contact us by email at Service@joy-it.net or by telephone.

Information on packaging:

If you do not have suitable packaging material or do not wish to use your own, please contact us and we will send you suitable packaging.

6. SUPPORT

If there are still any issues pending or problems arising after your purchase, we will support you by e-mail, telephone and with our ticket support system.

Email: service@joy-it.net

Ticket system: <http://support.joy-it.net>

Telephone: +49 (0)2845 9360-50 (10-17 o'clock)

For further information please visit our website:

www.joy-it.net