

3121, 3122, AND 3123

HALL-EFFECT SWITCHES FOR HIGH-TEMPERATURE OPERATION

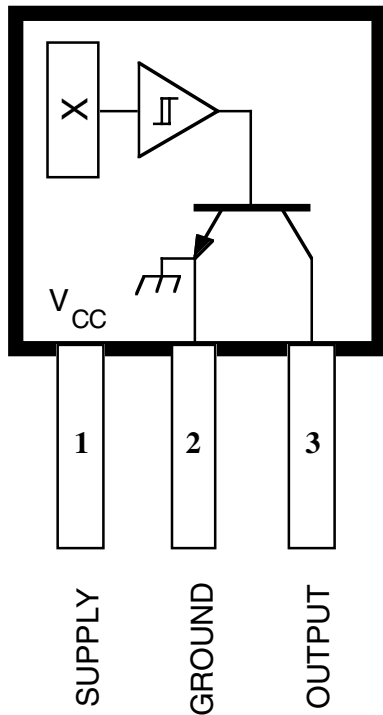

Dwg. PH-003A

Pinning is shown viewed from branded side.

ABSOLUTE MAXIMUM RATINGS at $T_A = +25^\circ\text{C}$

Supply Voltage, V_{CC}	30 V
Reverse Battery Voltage, V_{RCC}	-30 V
Magnetic Flux Density, B	Unlimited
Output OFF Voltage, V_{OUT}	28 V
Reverse Output Voltage, V_{OUT}	-0.5 V
Continuous Output Current, I_{OUT} ...	25 mA
Operating Temperature Range, T_A	
Suffix 'E-'	-40°C to +85°C
Suffix 'L-'	-40°C to +150°C
Storage Temperature Range,	
T_S	-65°C to +170°C

These Hall-effect switches are monolithic integrated circuits with tighter magnetic specifications, designed to operate continuously over extended temperatures to +150°C, and are more stable with both temperature and supply voltage changes. The unipolar switching characteristic makes these devices ideal for use with a simple bar or rod magnet. The three basic devices (3121, 3122, and 3123) are identical except for magnetic switch points.

Each device includes a voltage regulator for operation with supply voltages of 4.5 volts to 24 volts, reverse battery protection diode, quadratic Hall-voltage generator, temperature compensation circuitry, small-signal amplifier, Schmitt trigger, and an open-collector output to sink up to 25 mA. With suitable output pull up, they can be used with bipolar or CMOS logic circuits. The 3121 is an improved replacement for the 3113 and 3119.

The first character of the part number suffix determines the device operating temperature range. Suffix 'E-' is for the automotive and industrial temperature range of -40°C to +85°C. Suffix 'L-' is for the automotive and military temperature range of -40°C to +150°C. Three package styles provide a magnetically optimized package for most applications. Suffix '-LT' is a miniature SOT-89/TO-243AA transistor package for surface-mount applications; suffix '-U' is a three-lead plastic mini-SIP while suffix '-UA' is a three-lead ultra-mini-SIP.

FEATURES and BENEFITS

- Superior Temp. Stability for Automotive or Industrial Applications
- 4.5 V to 24 V Operation ... Needs Only An Unregulated Supply
- Open-Collector 25 mA Output ... Compatible with Digital Logic
- Reverse Battery Protection
- Activate with Small, Commercially Available Permanent Magnets
- Solid-State Reliability ... No Moving Parts
- Small Size
- Resistant to Physical Stress

Always order by complete part number, e.g., **A3121EU**.

3121, 3122, AND 3123 HALL-EFFECT SWITCHES FOR HIGH-TEMPERATURE OPERATION

ELECTRICAL CHARACTERISTICS over operating temperature range, at $V_{CC} = 12\text{ V}$.

Characteristic	Symbol	Test Conditions	Limits			
			Min.	Typ.	Max.	Units
Supply Voltage	V_{CC}	Operating	4.5	—	24	V
Output Saturation Voltage	$V_{OUT(SAT)}$	$I_{OUT} = 20\text{ mA}$, $B > B_{OP}$	—	140	400	mV
Output Leakage Current	I_{OFF}	$V_{OUT} = 24\text{ V}$, $B < B_{RP}$	—	<1.0	10	μA
Supply Current	I_{CC}	$B < B_{RP}$ (Output OFF)	—	4.6	9.0	mA
Output Rise Time	t_r	$R_L = 820\ \Omega$, $C_L = 20\text{ pF}$	—	0.04	2.0	μs
Output Fall Time	t_f	$R_L = 820\ \Omega$, $C_L = 20\text{ pF}$	—	0.18	2.0	μs

MAGNETIC CHARACTERISTICS in gauss over operating supply voltage range.

Characteristic	Part Numbers*								
	A3121			A3122			A3123		
	Min.	Typ.	Max.	Min.	Typ.	Max.	Min.	Typ.	Max.
B_{OP} at $T_A = 25^\circ\text{C}$	250	350	450	280	340	400	250	345	440
over operating temp. range	220	350	500	260	340	430	230	345	470
B_{RP} at $T_A = 25^\circ\text{C}$	125	245	380	140	235	330	180	240	300
over operating temp. range	80	245	410	120	235	360	160	240	330
B_{hys} at $T_A = 25^\circ\text{C}$	70	105	140	70	105	140	70	105	140
over operating temp. range	60	105	150	70	105	140	70	105	140

NOTES: Typical values are at $T_A = +25^\circ\text{C}$ and $V_{CC} = 12\text{ V}$.

B_{OP} = operate point (output turns ON); B_{RP} = release point (output turns OFF); B_{hys} = hysteresis ($B_{OP} - B_{RP}$).

*Complete part number includes a suffix to identify operating temperature range (E- or L-) and package type (-LT, -U, or -UA).

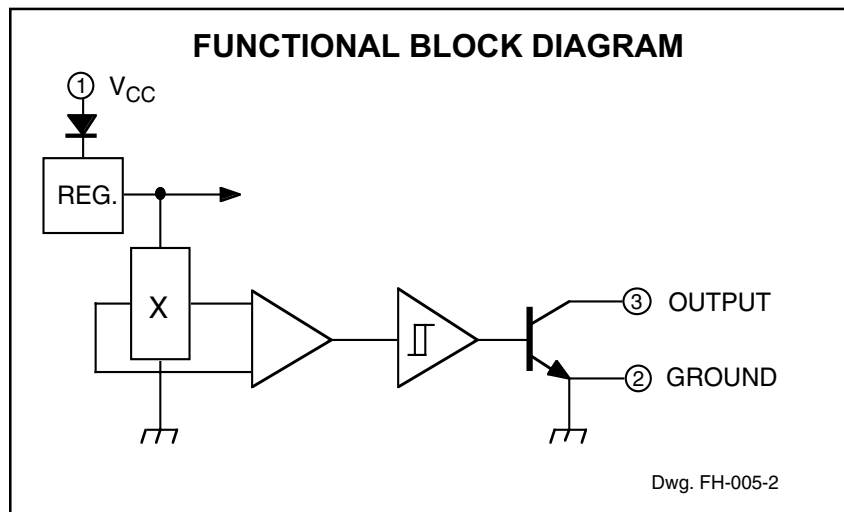

3121, 3122, AND 3123 HALL-EFFECT SWITCHES FOR HIGH-TEMPERATURE OPERATION

TYPICAL OPERATING CHARACTERISTICS

SWITCH POINTS

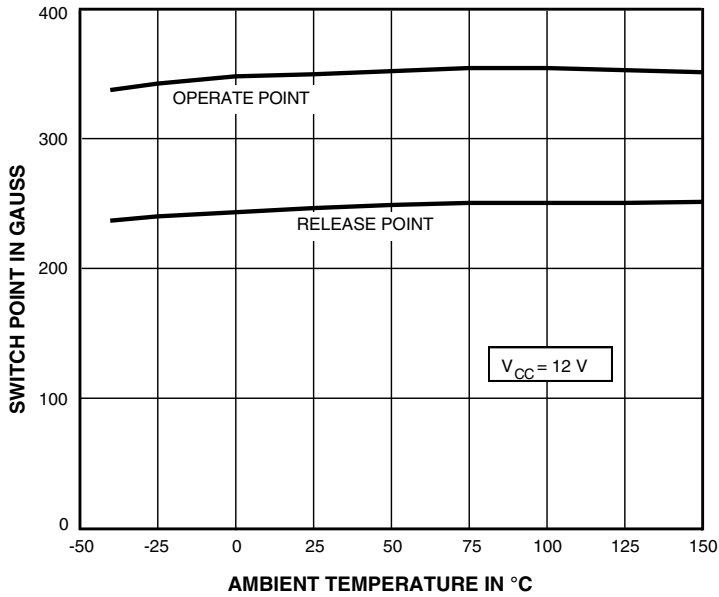

Dwg. GH-038

OUTPUT SATURATION VOLTAGE

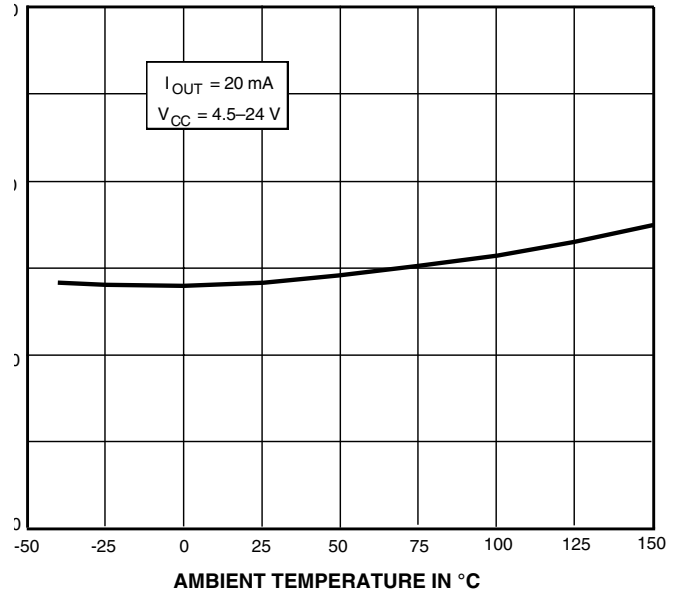

Dwg. GH-040

SUPPLY CURRENT

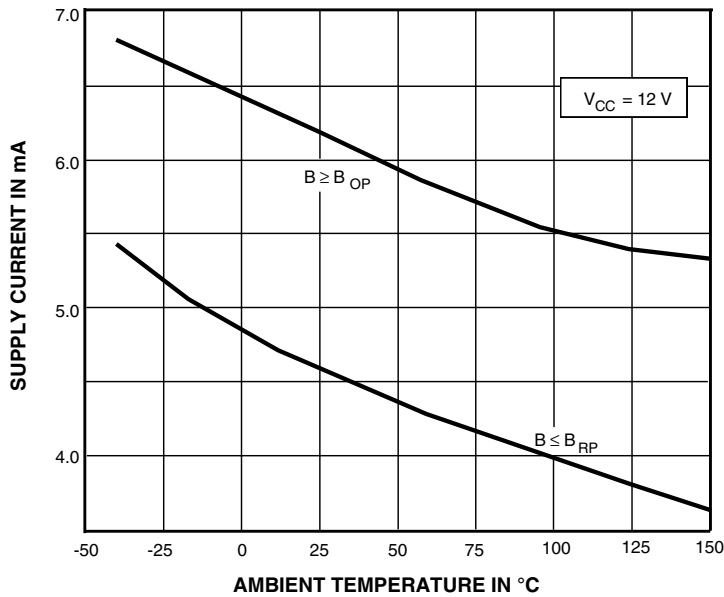

Dwg. GH-039

SUPPLY CURRENT

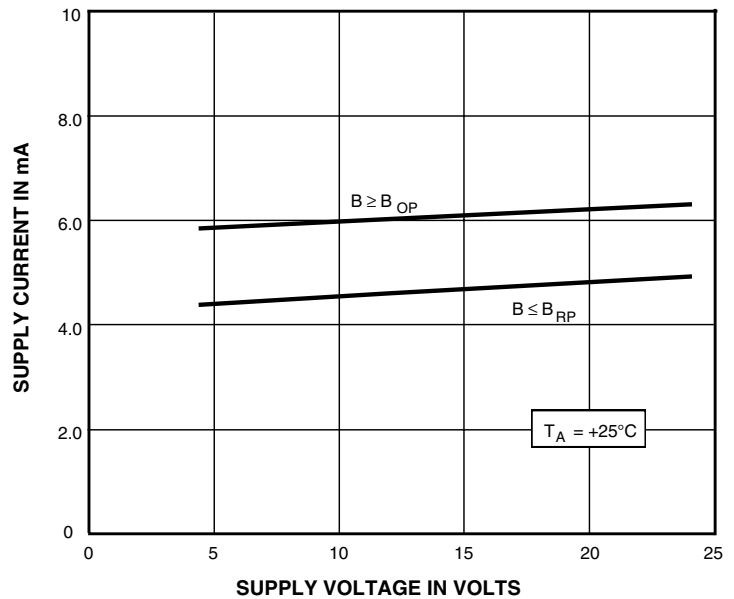

Dwg. GH-041

* Complete part number includes a suffix denoting operating temperature range (E- or L-) and package type (-LT, -U, or -UA).

3121, 3122, AND 3123 HALL-EFFECT SWITCHES FOR HIGH-TEMPERATURE OPERATION

SENSOR LOCATIONS

(±0.005" [0.13 mm] die placement)

Suffix "LT"

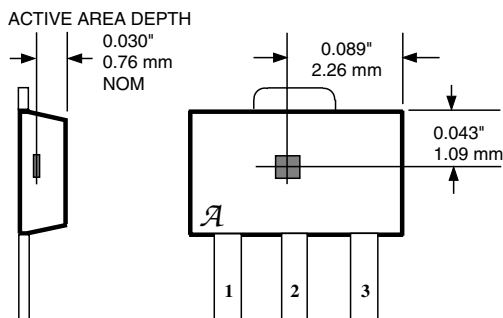

Suffix "U"

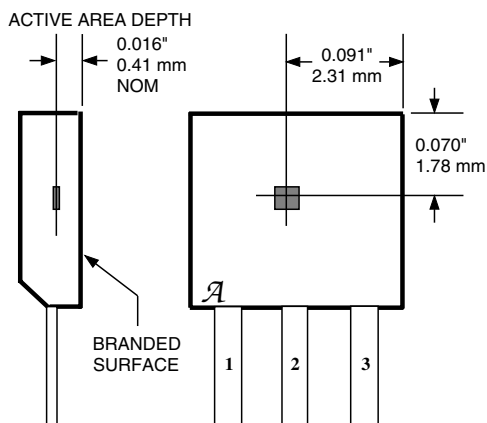

Suffix "UA"

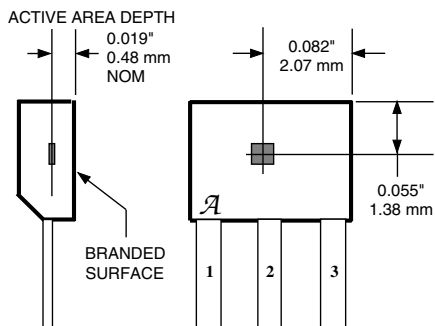

OPERATION

The output of these devices (pin 3) switches low when the magnetic field at the Hall sensor exceeds the operate point threshold (B_{OP}). At this point, the output voltage is $V_{OUT(SAT)}$. When the magnetic field is reduced to below the release point threshold (B_{RP}), the device output goes high. The difference in the magnetic operate and release points is called the hysteresis (B_{hys}) of the device. This built-in hysteresis allows clean switching of the output even in the presence of external mechanical vibration and electrical noise.

APPLICATIONS INFORMATION

Hall effect applications information is available in the "Hall-Effect IC Applications Guide", which can be found in the latest issue of *Allegro Microsystems Data Book AMS-702*.

CHANGE IN OPERATE POINT

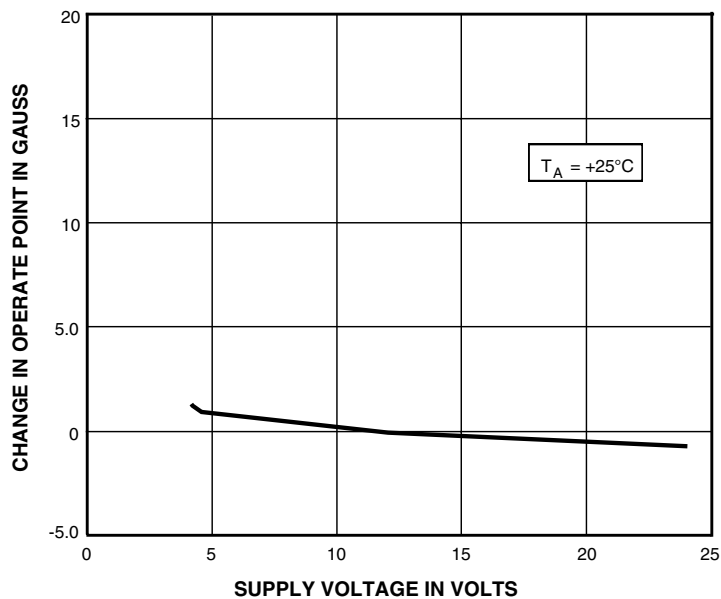

3121, 3122, AND 3123 HALL-EFFECT SWITCHES FOR HIGH-TEMPERATURE OPERATION

PACKAGE DESIGNATOR 'LT'

Dimensions in Inches
(for reference only)

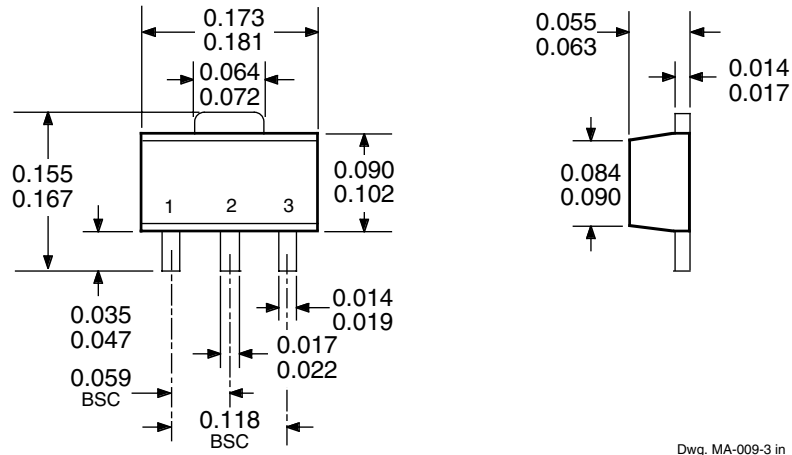

Dimensions in Millimeters
(controlling dimensions)

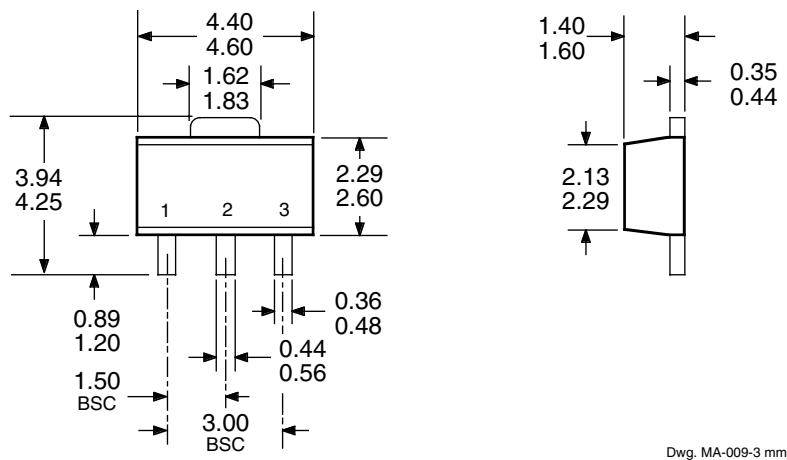

NOTE: Exact body and lead configuration at vendor's option within limits shown.

3121, 3122, AND 3123 HALL-EFFECT SWITCHES FOR HIGH-TEMPERATURE OPERATION

PACKAGE DESIGNATOR 'U'

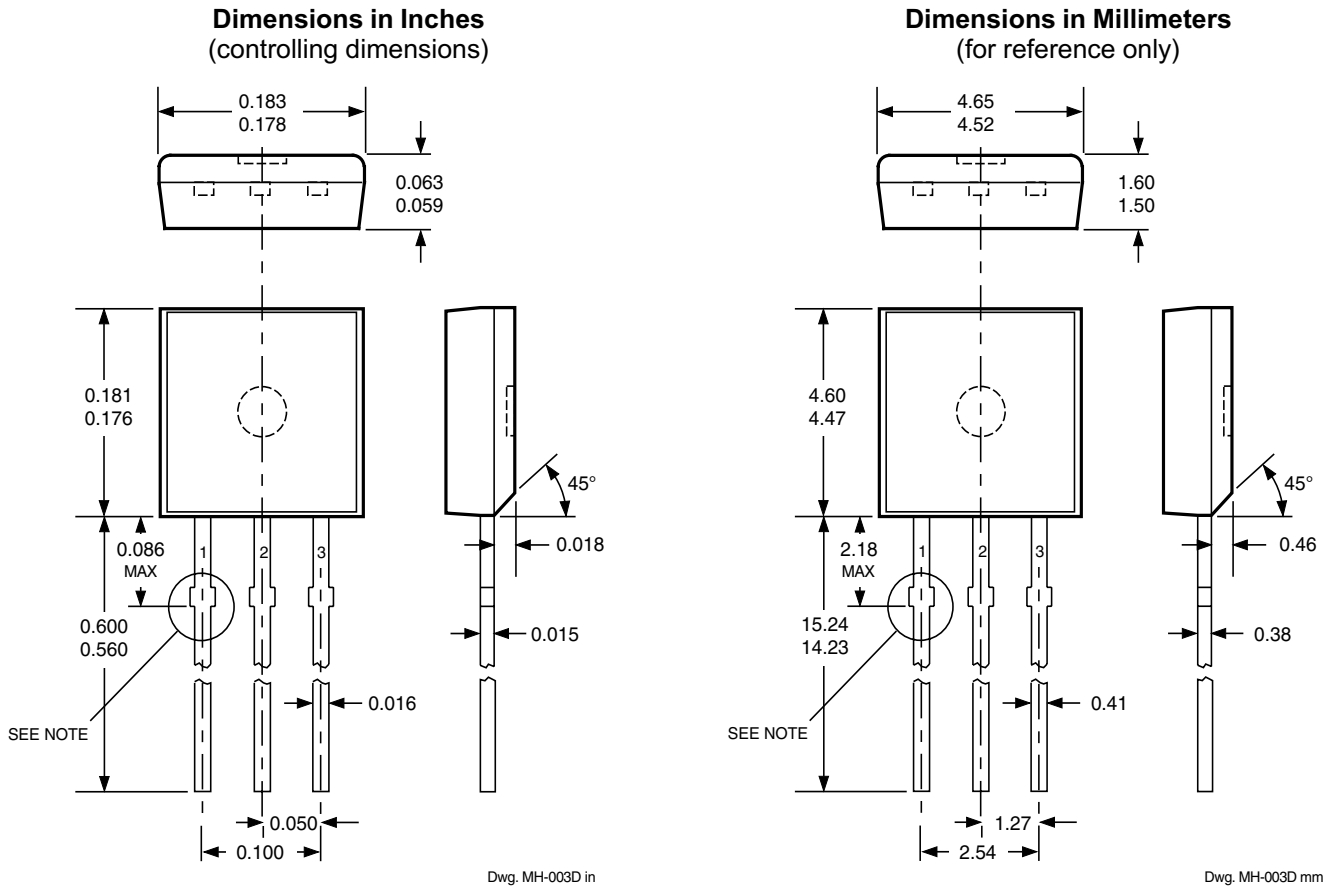

**Devices in the 'U' package are
NOT RECOMMENDED FOR NEW DESIGN**

- NOTES: 1. Tolerances on package height and width represent allowable mold offsets. Dimensions given are measured at the widest point (parting line).
2. Exact body and lead configuration at vendor's option within limits shown.
3. Height does not include mold gate flash.
4. Recommended minimum PWB hole diameter to clear transition area is 0.035" (0.89 mm).
5. Where no tolerance is specified, dimension is nominal.

3121, 3122, AND 3123 HALL-EFFECT SWITCHES FOR HIGH-TEMPERATURE OPERATION

PACKAGE DESIGNATOR 'UA'

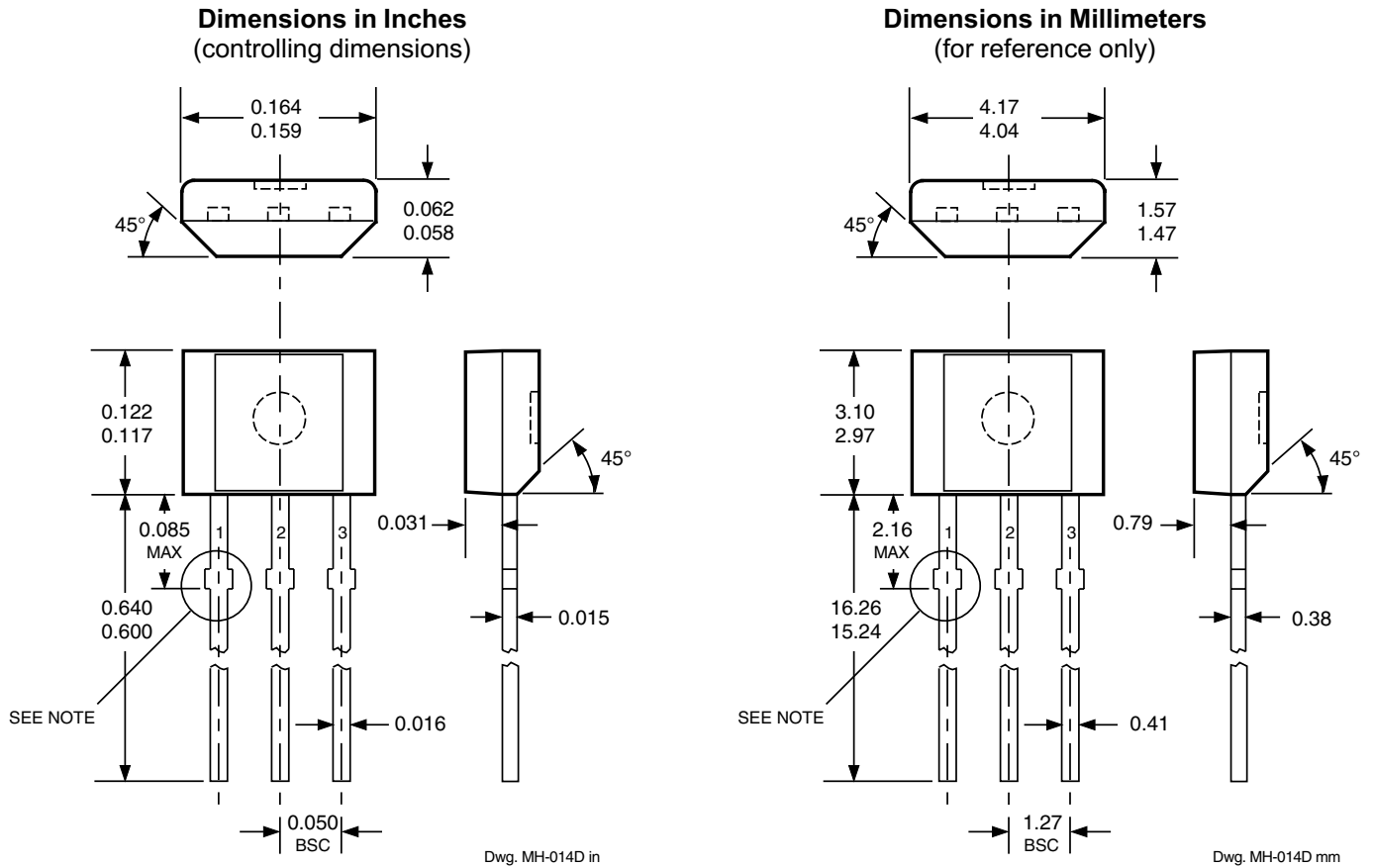

- NOTES: 1. Tolerances on package height and width represent allowable mold offsets. Dimensions given are measured at the widest point (parting line).
2. Exact body and lead configuration at vendor's option within limits shown.
3. Height does not include mold gate flash.
4. Recommended minimum PWB hole diameter to clear transition area is 0.035" (0.89 mm).
5. Where no tolerance is specified, dimension is nominal.

**3121, 3122, AND 3123
HALL-EFFECT SWITCHES
FOR HIGH-TEMPERATURE
OPERATION**

The products described herein are manufactured under one or more of the following U.S. patents: 5,045,920; 5,264,783; 5,442,283; 5,389,889; 5,581,179; 5,517,112; 5,619,137; 5,621,319; 5,650,719; 5,686,894; 5,694,038; 5,729,130; 5,917,320; and other patents pending.

Allegro MicroSystems, Inc. reserves the right to make, from time to time, such departures from the detail specifications as may be required to permit improvements in the performance, reliability, or manufacturability of its products. Before placing an order, the user is cautioned to verify that the information being relied upon is current.

Allegro products are not authorized for use as critical components in life-support appliances, devices, or systems without express written approval.

The information included herein is believed to be accurate and reliable. However, Allegro MicroSystems, Inc. assumes no responsibility for its use; nor for any infringements of patents or other rights of third parties that may result from its use.



This datasheet has been downloaded from:

www.DatasheetCatalog.com

Datasheets for electronic components.