

ESP8266

WiFi module

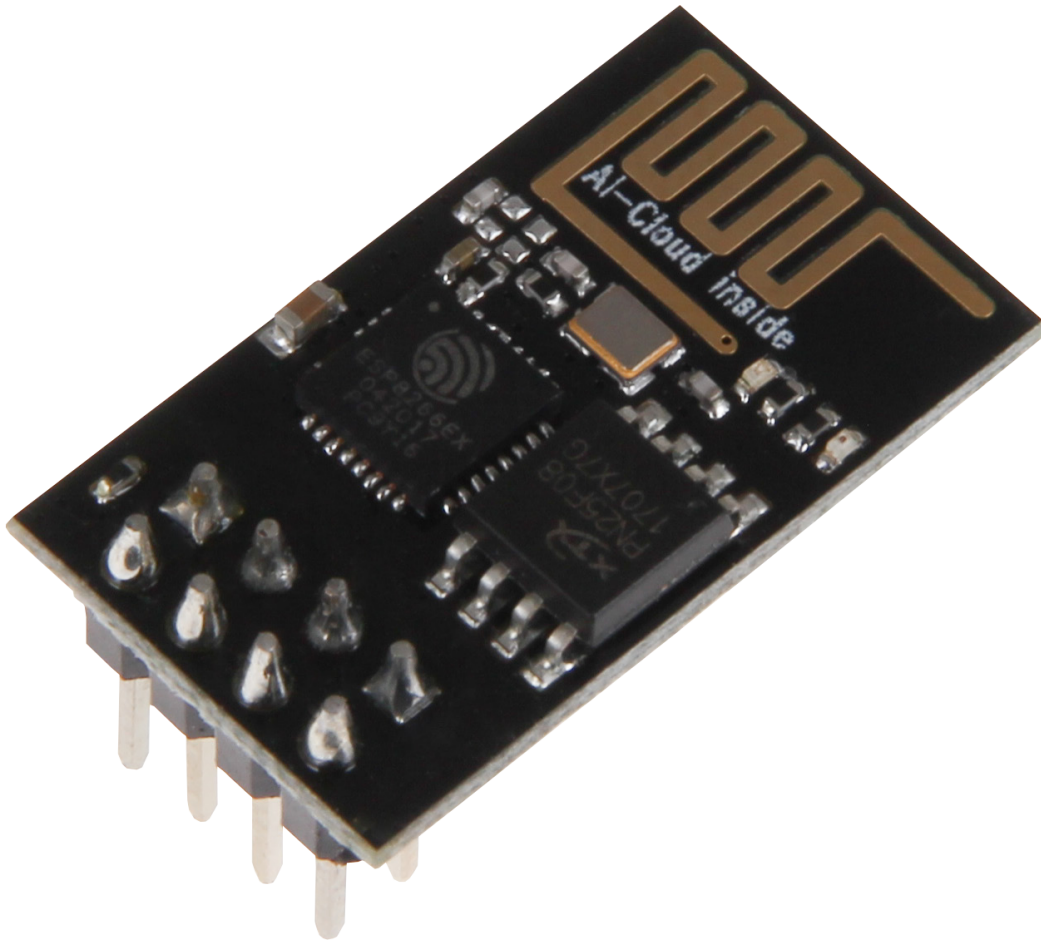

1. GENERAL INFORMATION

Dear customer,

thank you for choosing our product. In the following, we will show what you should note at the commissioning and during the usage.

Should you encounter any unexpected problems during use, please do not hesitate to contact us.

2. INITIAL SETUP

Open the preferences of your Arduino program and add the following line to the **additional board manager URLs** like shown in the following pictures:

http://arduino.esp8266.com/stable/package_esp8266com_index.json

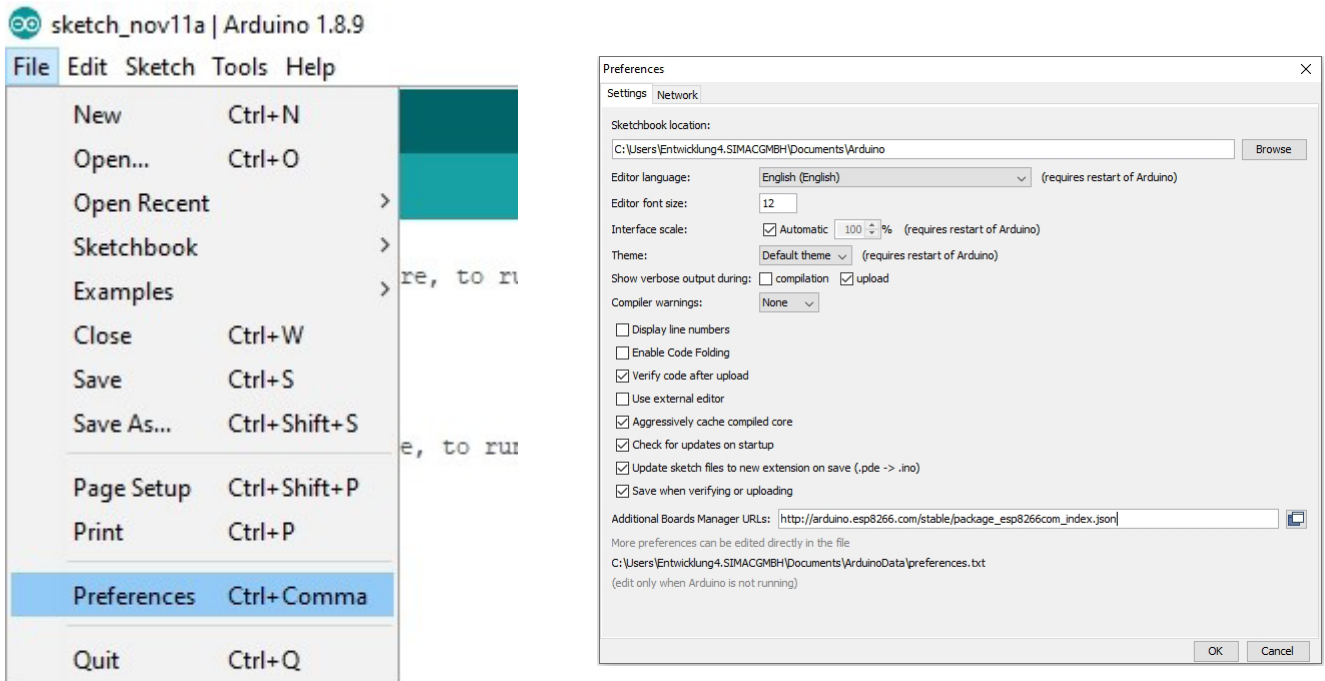

Download the additional data of the ESP8266 from the board manager.

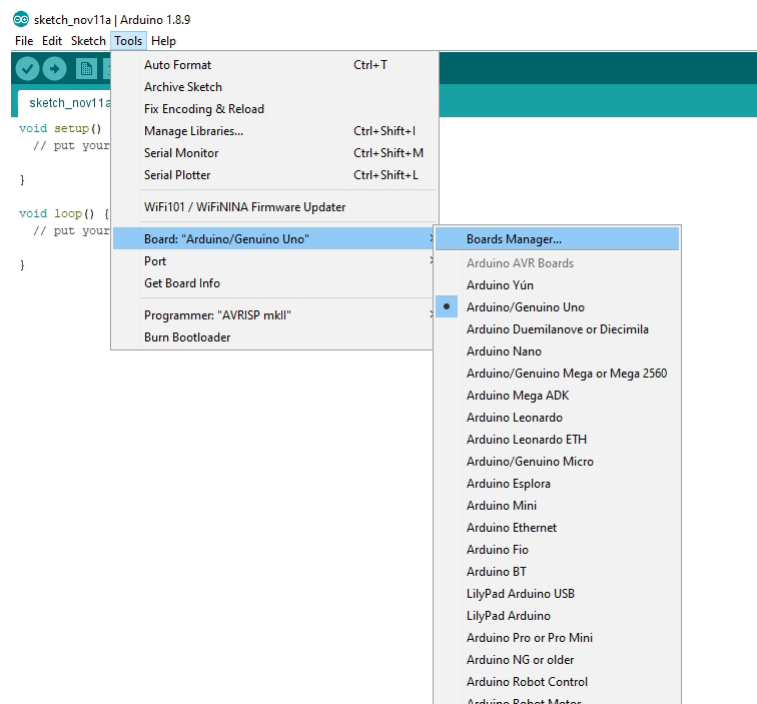



Select now the ESP8266 as the board.



Attention! Please note that you must select the accurate port from the menu “**Port**” which is beneath the board manager.

3. CONNECTION OF THE MODULE

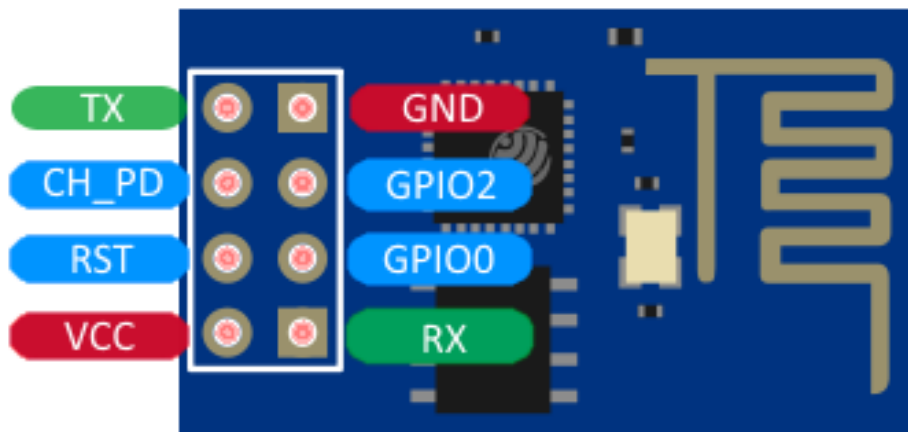

Use with a TTL-cable



Attention! Please note that the TTL-adapter unit is set on a voltage supply of 3.3 V and a current supply of 350 mA. Verify this if necessary.

Connect the module with the TTL-cable with the aid of the following chart.
The pin assignment of the ESP8266 can be seen in the picture above.

ESP8266	TTL-Kabel
RX	TX
TX	RX
GND	GND
VCC	3.3 V
CH_PD	3.3 V
GPIO0	3.3 V

Use with an Arduino Uno

Connect the module with the Arduino Uno with the aid of the following chart or rather the following picture.
The pin assignment of the ESP8266 can be seen in the above-named picture.

ESP8266	Arduino Uno
RX	Pin 1
TX	Pin 0
GND	GND
VCC	3.3 V
CH_PD	3.3 V
GPIO0	3.3 V

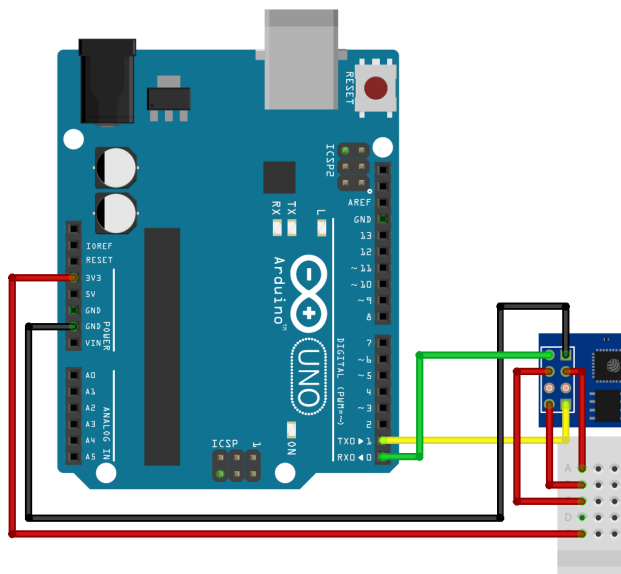

4. CODE TRANSMISSION

In the following, we demonstrate the transmission of the code with the code example from the ESP8266-library.

To transfer the code to the ESP8266, you have to select the desired code example from the example menu of the Arduino software.

The used baudrate (“**Upload Speed**“ in the menu “**Tools**“) for the transmission should be 115200.

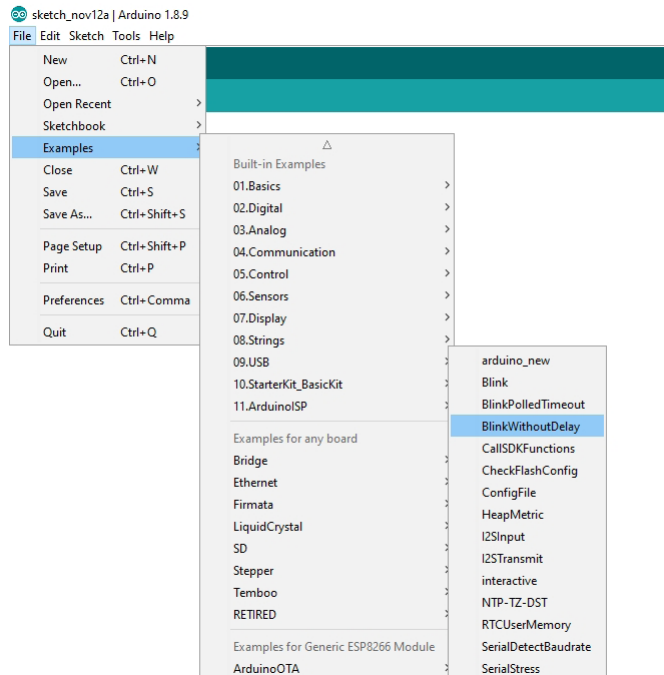

Attention! Before you can transfer the new code to the ESP8266, you must set the module into the programming mode:

For the use with a TTL-cable:

Separate the power supply (VCC) from the ESP8266 module and connect them again afterwards. The module should start in the programming mode. If you do not have any success with this method, you can try the Arduino method.

In some cases this alternative works better even with the TTL-cable.

For the use with an Arduino:

Separate the power supply (VCC) from the module and set the GPIO0 pin from 3.3 V to 0 V (GND). After that restore the power supply.

As soon as the software has been transferred, the module can be set again into the normal operation status.

For this, separate again the current supply, set the GPIO0 pin to 3.3 V and restore the power supply.

When you have set the module into the programming mode, you can start the transmission. Do not forget that you must switch back to the normal operation status after the transmission is finished.

5. FURTHER INFORMATION

Our information and redemption obligation according to the electro-law (ElektroG)



Symbol on electrical and electronic products :

This crossed-out bin means that electrical and electronic products do **not** belong into the household waste. You must hand over your old appliance to a registration office. Before you can hand over the old appliance, you must remove used batteries and accumulators which are not enclosed by the device.

Return options :

As the end user, you can hand over with the purchase of a new device your old appliance (which has essentially the same functions as the new one) free of charge for disposal. Small devices which do not have outer dimensions greater than 25 cm can be submitted independently of the purchase of a new product in normal household quantities.

Possibility of restitution at our company location during our opening hours :

Simac GmbH, Pascalstr. 8, D-47506 Neukirchen-Vluyn

Possibility of restitution nearby :

We send you a parcel stamp with which you can send us your old appliance free of charge. For this possibility, you must contact us via e-mail at service@joy-it.net or via telephone.

Information about packaging:

Please package your old appliance safe during transport. Should you not have a suitable packaging material or you do not want to use your own material, you can contact us and we will send you an appropriate package.



6. SUPPORT

If any questions remain open or problems arise after your purchase, we are available by e-mail, telephone and with a ticket support system to answer these.

E-Mail: service@joy-it.net

Ticket-System: <http://support.joy-it.net>

Telephone: +49 (0)2845 98469 – 66 (10 - 17 o'clock)

For further information visit our website:

www.joy-it.net