

HFD17

SUBMINIATURE SIGNAL RELAY



File No.: E133481



File No.:R50431434

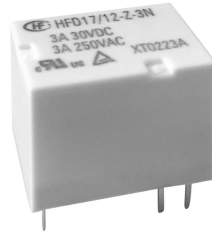

Features

- 8A switching capability
- UL insulation system: Class F available
- Plastic sealed and flux proofed types available
- Standard PCB layout
- Product in accordance to IEC 60335-1 available

RoHS compliant

CONTACT DATA

Contact arrangement	1C
Contact resistance ¹⁾	100mΩ max. (AgNi gold-plated specifications: 0.1A 6VDC, AgNi non gold-plated specifications and AgSnO ₂ :1A 6VDC)
Contact material	AgNi, AgSnO ₂
Contact rating (Res. load)	3A 30VDC 3A 250VAC
Max. switching voltage	250VAC / 220VDC
Max. switching current	8A
Max. switching power	750VA / 90W
Min. applicable load	5V 1mA(Suitable for AgNi gold-plated specifications)
Mechanical endurance	1 x 10 ⁷ OPS
Electrical endurance	1x10 ⁶ OPS(AgNi, 85°C, 1s on 9s off, NO. HFD17:3A 125VAC HFD17-1:1A 125VAC)

Notes: 1) The data shown above are initial values.

2)Min. applicable load is reference value. Please perform the confirmation test with the actual load before production since reference value may change according to switching frequencies, environmental conditions and expected contact resistance and reliability.

CHARACTERISTICS

Insulation resistance	1000MΩ (at 500VDC)	
Dielectric strength	between open contacts	750VAC 1min
	between coil & contacts	1500VAC 1min
Surge withstand voltage		
between open contacts(10/160 μ s)	1500V(FCC part 68)	
between coil & contacts(2/10 μ s)	2000V(Telecordia)	
Operate time (at rated voltage.)	5ms max.	
Release time (at rated voltage.)	5ms max.	
Ambient temperature	-40°C to 85°C	
Humidity	5% to 85% RH	
Shock resistance	Functional	147m/s ²
	Destructive	980m/s ²
Vibration resistance	Functional	10Hz to 55Hz 2.5mm DA
	Destructive	10Hz to 55Hz 5mm DA
Termination	DIP	
Unit weight	Approx. 4g	
Construction	Plastic sealed Flux proofed	

Notes: 1) The data shown above are initial values.

2) UL insulation system: Class F.



HONGFA RELAY

ISO9001, ISO/TS16949, ISO14001, OHSAS18001, IECQ QC 080000 CERTIFIED

2020 Rev. 1.00

COIL

Coil power	200mW;
------------	--------

COIL DATA

at 23°C

Nominal Voltage VDC	Pick-up Voltage VDC ¹⁾ max.	Drop-out Voltage VDC ¹⁾ min.	Max. Voltage ²⁾ VDC	Coil Resistance x (1±10%) Ω
				Standard
2.4	≤1.80	≥0.24	3.12	28.8
3	≤2.25	≥0.3	3.90	45.0
4.5	≤3.38	≥0.45	5.85	101.3
5	≤3.75	≥0.5	6.50	120
6	≤4.5	≥0.6	6.63	180
9	≤6.75	≥0.9	11.7	400
12	≤9.00	≥1.2	15.6	700
18	≤13.5	≥1.8	23.4	1620
24	≤18.0	≥2.4	31.2	2800

Notes: 1) The data shown above are initial values.

2)Maximum voltage refers to the maximum voltage which relay coil could endure in a short period of time.

SAFETY APPROVAL RATINGS

		HFD17	HFD17-1
UL/CUL	AgNi	3A 125VAC,85°C 3A 250VAC,Room temp 3A 30VDC,85°C	1A 125VAC,85°C 1A 250VAC,Room temp 1A 30VDC,85°C
	AgSnO ₂	3A 250VAC,85°C 3A 30VDC,85°C TV-1 125VAC,Room temp	1A 250VAC,85°C 1A 30VDC,85°C
TÜV	AgNi	3A 125VAC,85°C 3A 250VAC,Room temp 3A 30VDC,85°C	1A 250VAC,85°C 1A 250VAC,Room temp 1A 30VDC,85°C
	AgSnO ₂	3A 250VAC,85°C 3A 30VDC,85°C 1(1) 250VAC,Room temp	1A 250VAC,85°C 1A 30VDC,85°C 1(1) 250VAC,Room temp

Notes: 1)Only typical loads are listed above. Other load specifications can be available upon request.

ORDERING INFORMATION

		HFD17/	24	-Z	F	-3	N	(XXX)
Type	HFD17:3A contact rating HFD17-1:1A contact rating							
Coil voltage	2.4, 3, 4.5, 5, 6, 9, 12, 18, 24 VDC							
Contact arrangement	Z:1 Form C							
Construction	F: Flux proofed		Nil: Plastic sealed					
Contact material	3: AgNi		T: AgSnO ₂					
Contact plating	N: No gold plated		Nil: Gold plated(Only for AgNi type)					
Special code¹⁾	XXX: Customer special requirement							

Notes: 1) The customer special requirement express as special code after evaluating by Hongfa.

2) For products that should meet the explosion-proof requirements of "IEC 60079 series", please note [Ex] after the specification while placing orders. Not all products have explosion-proof certification, so please contact us if necessary, in order to select the suitable products.

OUTLINE DIMENSIONS, WIRING DIAGRAM AND PC BOARD LAYOUT

Unit: mm

Outline Dimensions

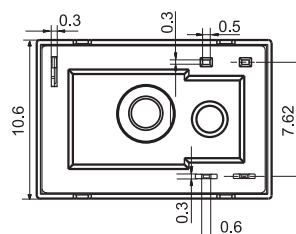
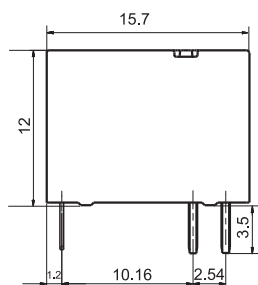

(Bottom view)

PCB Layout

(Bottom view)

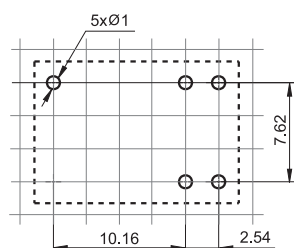

Wiring Diagram

(Bottom view)

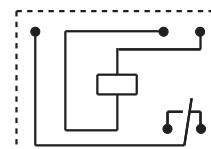

Remark: 1) In case of no tolerance shown in outline dimension: outline dimension ≤ 1 mm, tolerance should be ± 0.2 mm; outline dimension > 1 mm and ≤ 5 mm, tolerance should be ± 0.3 mm; outline dimension > 5 mm, tolerance should be ± 0.4 mm.

2) The tolerance without indicating for PCB layout is always ± 0.1 mm.

3) The width of the gridding is 2.5mm.

CHARACTERISTIC CURVES

HFD17

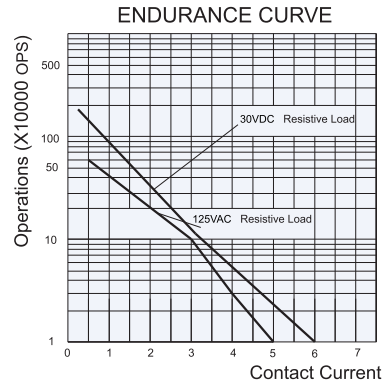
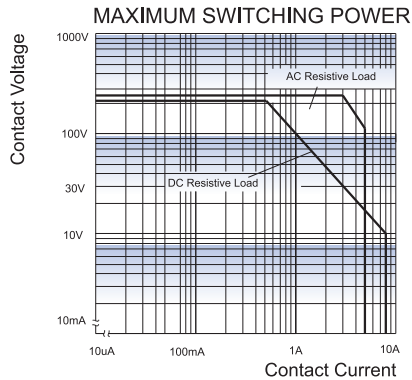

Test conditions:

AgNi, NO contact ,Resistive load, 85°C.

HFD17-1

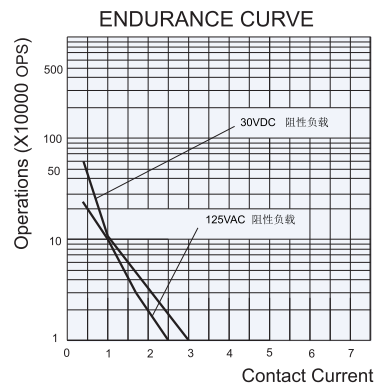
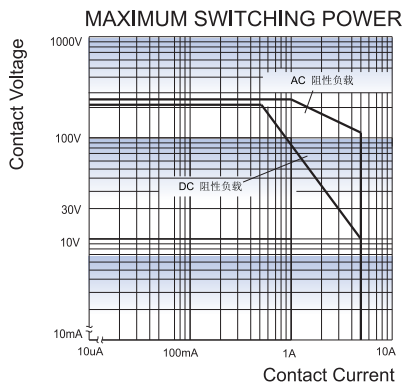

Test conditions:

AgNi, NO contact ,Resistive load, 85°C.

Notice

- 1) To avoid using relays under strong magnetic field which will change the parameters of relays such as pick-up voltage and drop-out voltage.
- 2) Energizing coil with rated voltage is basic for normal operation of a relay, please make sure the energized voltage to relay coil have reached the rated voltage.
- 3) The relay may be damaged because of falling or when shocking conditions exceed the requirement.
- 4) Plastic sealed type is recommended for an environment with noxious gas such as H₂S, SO₂ and NO₂,ect., and/or when load current is low, and/or the PCB boards need to be washed after relays are soldered. For other using conditions flux proofed type could be adopted.
- 5) Contact is recommended for suitable condition and specifications if water cleaning or surface process is involved in assembling relays on PCB.
- 6) Regarding the plastic sealed relay, we should leave it cooling naturally untill below 40°C after welding, then clean it and deal with coating, remarkably the temperature of solvents should also be controlled below 40°C. Please avoid cleaning the relay by ultrasonic, avoid using the solvents like gasoline, Freon, and so on, which would affect the configuration of relay or influence the environment.
- 7) About preferable condition of operation, storage and transportation, please refer to "Explanation to terminology and guidetines of relay".
- 8) Please contact us for more details if you have different conditions of application.

Disclaimer

The specification is for reference only. See to "Terminology and Guidelines" for more information. Specifications subject to change without notice. We could not evaluate all the performance and all the parameters for every possible application. Thus the user should be in a right position to choose the suitable product for their own application. If there is any query, please contact Hongfa for the technical service. However, it is the user's responsibility to determine which product should be used only.